

Self-priming "JET" pumps

-  Clean water
-  Domestic use
-  Civil use
-  Industrial use



PERFORMANCE RANGE

- Flow rate up to **160 l/min** (9.6 m³/h)
- Head up to **97 m**

APPLICATION LIMITS

- Manometric suction lift up to **9 m** (HS)
- Liquid temperature between **-10 °C** and **+40 °C**
- Ambient temperature up to **+40 °C**
- Max. working pressure **10 bar**
- Continuous service **S1**

CONSTRUCTION AND SAFETY STANDARDS

EN 60335-1
IEC 60335-1
CEI 61-150

EN 60034-1
IEC 60034-1
CEI 2-3



CERTIFICATIONS

Company with management system certified DNV
ISO 9001: QUALITY



INSTALLATION AND USE

Suitable for use with clean water and with liquids that are not chemically aggressive towards the materials from which the pump is made. The self-priming **JSW** pumps are designed to pump water even in cases where air is present. Because of their reliability and the fact that they are easy to use, they are recommended for use in domestic, civil and industrial applications such as the distribution of water in combination with pressure tanks, and for the irrigation of gardens and orchards, etc. Installation needs to be undertaken in well ventilated closed areas or anyway protected from bad weather.

PATENTS - TRADE MARKS - MODELS

- Registered Trade Mark n. 013073135 JSW[®]
- Registered EU Design n. 002218610

OPTIONS AVAILABLE ON REQUEST

- Other voltages or 60 Hz frequency
- IPX5 protection

CHARACTERISTIC CURVES AND PERFORMANCE DATA

50 Hz n= 2900 min⁻¹ HS= 0 m

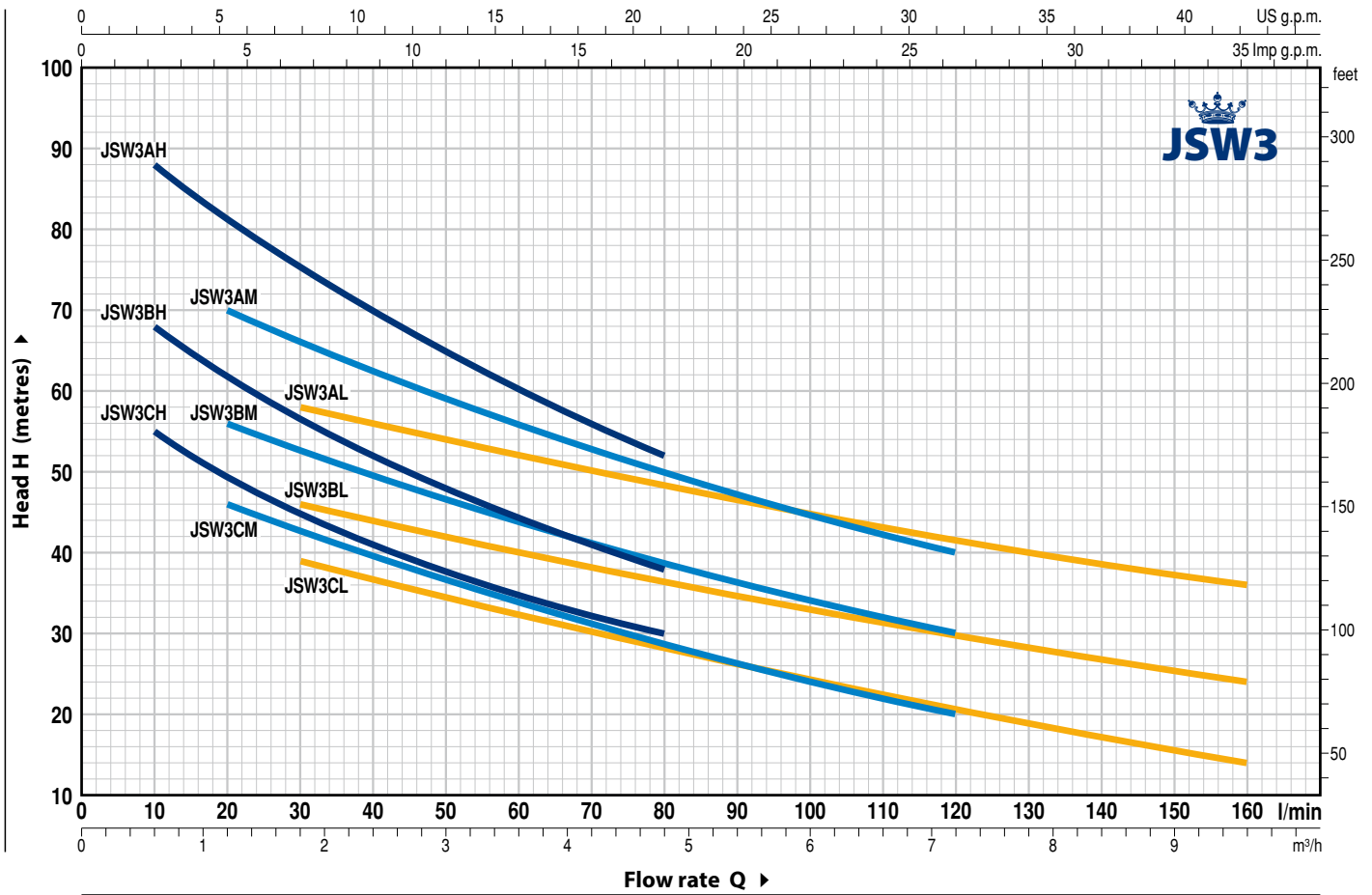

| MODEL | | POWER (P ₂) | | ▲ | Q | Flow rate | | | | | | | | | | | | | | | |
|--------------|-------------|-------------------------|-----|-----|----------|-------------------|----|-----|------|------|------|------|-----|------|-----|-----|-----|-----|-----|--|--|
| Single-phase | Three-phase | kW | HP | | | m ³ /h | 0 | 0.6 | 1.2 | 1.8 | 2.4 | 3.0 | 3.6 | 4.2 | 4.8 | 6.0 | 7.2 | 8.4 | 9.6 | | |
| JSWm 3CH | JSW 3CH | 1.1 | 1.5 | IE3 | H metres | 0 | 10 | 20 | 30 | 40 | 50 | 60 | 70 | 80 | 100 | 120 | 140 | 160 | | | |
| JSWm 3BH | JSW 3BH | 1.5 | 2 | | | 62 | 55 | 49 | 45 | 41 | 38 | 35 | 32 | 30 | | | | | | | |
| JSWm 3AH | JSW 3AH | 2.2 | 3 | | | 73 | 68 | 62 | 56.5 | 52 | 48 | 44 | 41 | 38 | | | | | | | |
| JSWm 3CM | JSW 3CM | 1.1 | 1.5 | | | 97 | 88 | 81 | 75 | 70 | 65 | 60.5 | 56 | 52 | | | | | | | |
| JSWm 3BM | JSW 3BM | 1.5 | 2 | | | 54 | - | 46 | 43 | 39.5 | 36.5 | 34 | 31 | 28.5 | 24 | 20 | | | | | |
| JSWm 3AM | JSW 3AM | 2.2 | 3 | | | 63 | - | 56 | 53 | 49.5 | 47.5 | 44 | 41 | 39 | 34 | 30 | | | | | |
| JSWm 3CL | JSW 3CL | 1.1 | 1.5 | | | 78 | - | 70 | 66 | 62 | 59 | 56 | 53 | 50 | 45 | 40 | | | | | |
| JSWm 3BL | JSW 3BL | 1.5 | 2 | | | 44 | - | - | 39 | 37 | 34 | 32 | 30 | 28 | 24 | 21 | 17 | 14 | | | |
| JSWm 3AL | JSW 3AL | 2.2 | 3 | | | 51 | - | - | 46 | 44 | 42 | 40 | 38 | 36 | 33 | 30 | 27 | 24 | | | |
| | | | | | | | | | | | | | | | | | | | | | |

Q = Flow rate H = Total manometric head HS = Suction height

Tolerance of characteristic curves in compliance with EN ISO 9906 Grade 3B.

▲ Three-phase motor efficiency class (IEC 60034-30-1)

STANDARD INSTALLATION

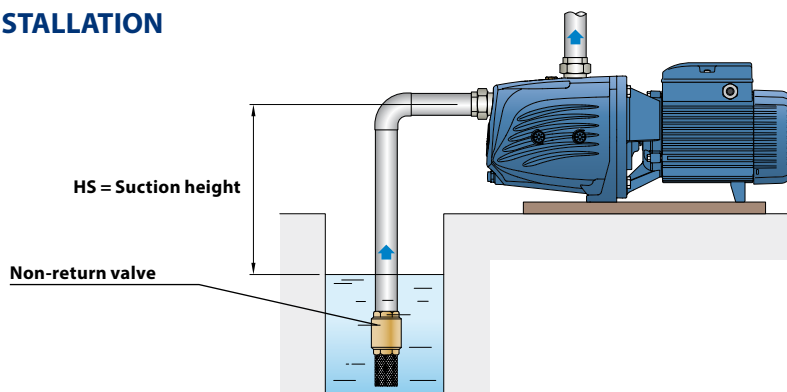

POS. COMPONENT CONSTRUCTION CHARACTERISTICS

| | | | | | | |
|---|------------------------|--|-------------------------|------------------------|------------------------|------------------|
| 1 | PUMP BODY | Cast iron with an Epoxy Electro Coating treatment, with threaded ports in compliance with ISO 228/1 | | | | |
| 2 | BODY BACKPLATE | Cast iron | | | | |
| 3 | NOZZLE ASSEMBLY | Noryl FE1520PW | | | | |
| 4 | IMPELLER | Stainless steel AISI 304 | | | | |
| 5 | MOTOR SHAFT | Stainless steel AISI 431 | | | | |
| 6 | MECHANICAL SEAL | Seal | Shaft | Materials | | |
| | | Model | Diameter | Stationary ring | Rotational ring | Elastomer |
| | | FN-18 | Ø 18 mm | Graphite | Ceramic | NBR |
| 7 | BEARINGS | 6204 ZZ / 6204 ZZ | | | | |
| 8 | CAPACITOR | Pump | Capacitance | | | |
| | | <i>Single-phase</i> | <i>(230 V or 240 V)</i> | <i>(110 V)</i> | | |
| | | JSWm 3C | 31.5 µF - 450 VL | 60 µF - 250 VL | | |
| | | JSWm 3B | 45 µF - 450 VL | 80 µF - 250 VL | | |
| | | JSWm 3A | 50 µF - 450 VL | - | | |
| 9 | ELECTRIC MOTOR | JSWm: single-phase 230 V - 50 Hz with thermal overload protector incorporated into the winding. JSW: three-phase 230/400 V - 50 Hz. ⇒ The three-phase pumps are fitted with high performance motors in class IE3 (IEC 60034-30-1) – Insulation: class F – Protection: IP X4 | | | | |

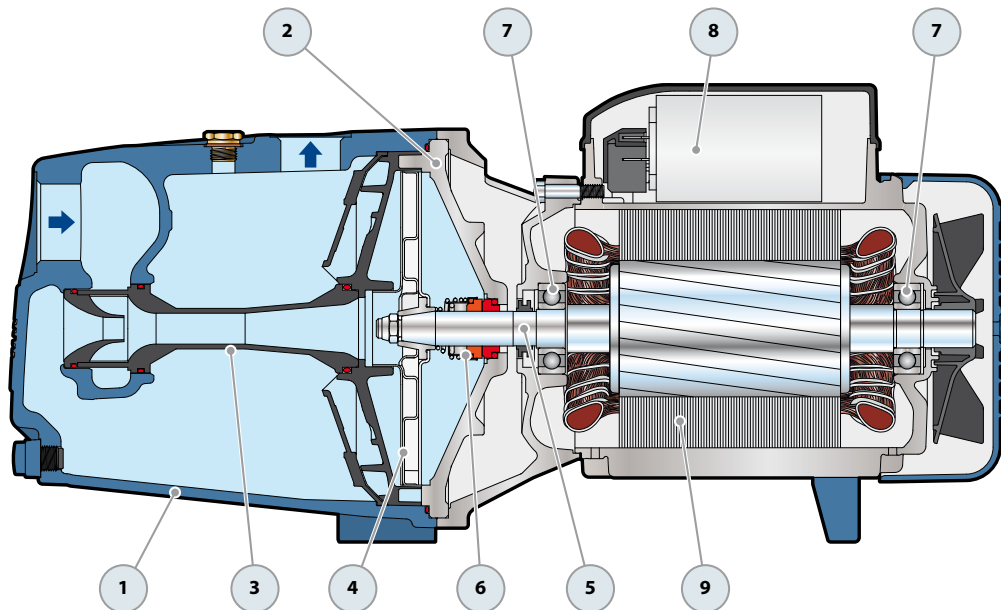

DIMENSIONS AND WEIGHT

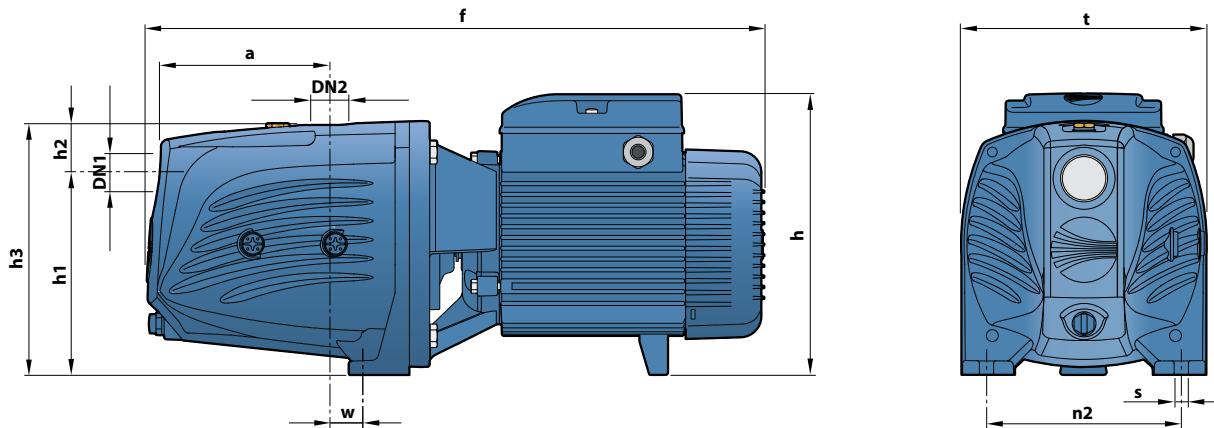

| MODEL | | PORTS | | DIMENSIONS mm | | | | | | | | | | kg | |
|--------------|-------------|-------|-----|---------------|------|-----|-----|----|-----|-----|-----|----|----|------|------|
| Single-phase | Three-phase | DN1 | DN2 | a | f | h | h1 | h2 | h3 | t | n2 | w | s | 1~ | 3~ |
| JSWm 3CH | JSW 3CH | 1¼" | 1" | 143 | 522 | 240 | 165 | 39 | 204 | 206 | 164 | 30 | 11 | 24.2 | 28.2 |
| JSWm 3BH | JSW 3BH | | | | 25.5 | | | | | | | | | 25.4 | |
| JSWm 3AH | JSW 3AH | | | | 28.2 | | | | | | | | | 28.0 | |
| JSWm 3CM | JSW 3CM | | | | 24.4 | | | | | | | | | 24.4 | |
| JSWm 3BM | JSW 3BM | | | | 25.6 | | | | | | | | | 25.5 | |
| JSWm 3AM | JSW 3AM | | | | 28.0 | | | | | | | | | 28.2 | |
| JSWm 3CL | JSW 3CL | | | | 24.4 | | | | | | | | | 24.3 | |
| JSWm 3BL | JSW 3BL | | | | 25.6 | | | | | | | | | 25.5 | |
| JSWm 3AL | JSW 3AL | | | | 28.2 | | | | | | | | | 28.2 | |

ABSORPTION

| MODEL | VOLTAGE | | |
|--------------|---------|--------|--------|
| Single-phase | 230 V | 240 V | 110 V |
| JSWm 3CH | 8.1 A | 7.8 A | 16.2 A |
| JSWm 3BH | 9.5 A | 9.2 A | 19.0 A |
| JSWm 3AH | 12.7 A | 12.4 A | - |
| JSWm 3CM | 8.1 A | 7.8 A | 16.2 A |
| JSWm 3BM | 9.7 A | 9.4 A | 19.4 A |
| JSWm 3AM | 13.0 A | 12.5 A | - |
| JSWm 3CL | 8.1 A | 7.8 A | 16.2 A |
| JSWm 3BL | 10.1 A | 9.8 A | 20.2 A |
| JSWm 3AL | 13.6 A | 13.1 A | - |

| MODEL | VOLTAGE | | | | | |
|-------------|---------|-------|-------|-------|-------|-------|
| Three-phase | 230 V | 400 V | 690 V | 240 V | 415 V | 720 V |
| JSW 3CH | 5.2 A | 3.0 A | 1.7 A | 5.0 A | 2.9 A | 1.7 A |
| JSW 3BH | 6.0 A | 3.5 A | 2.0 A | 5.8 A | 3.4 A | 1.9 A |
| JSW 3AH | 8.8 A | 5.1 A | 2.9 A | 8.5 A | 4.9 A | 2.8 A |
| JSW 3CM | 5.2 A | 3.0 A | 1.7 A | 5.0 A | 2.9 A | 1.7 A |
| JSW 3BM | 6.0 A | 3.5 A | 2.0 A | 5.8 A | 3.4 A | 1.9 A |
| JSW 3AM | 9.0 A | 5.2 A | 3.0 A | 8.6 A | 5.0 A | 2.9 A |
| JSW 3CL | 5.2 A | 3.0 A | 1.7 A | 5.0 A | 2.9 A | 1.7 A |
| JSW 3BL | 6.4 A | 3.7 A | 2.1 A | 6.1 A | 3.6 A | 2.0 A |
| JSW 3AL | 9.3 A | 5.4 A | 3.1 A | 9.0 A | 5.2 A | 3.0 A |

PALLETIZATION

| MODEL | | GROUPAGE | CONTAINER |
|--------------|-------------|----------|-----------|
| Single-phase | Three-phase | n. pumps | n. pumps |
| JSWm 3CH | JSW 3CH | 35 | 49 |
| JSWm 3BH | JSW 3BH | 35 | 49 |
| JSWm 3AH | JSW 3AH | 35 | 49 |
| JSWm 3CM | JSW 3CM | 35 | 49 |
| JSWm 3BM | JSW 3BM | 35 | 49 |
| JSWm 3AM | JSW 3AM | 35 | 49 |
| JSWm 3CL | JSW 3CL | 35 | 49 |
| JSWm 3BL | JSW 3BL | 35 | 49 |
| JSWm 3AL | JSW 3AL | 35 | 49 |