



Self-priming "JET" pumps

 Clean water

 Domestic use



PERFORMANCE RANGE

- Flow rate up to **60 l/min** (3.6 m³/h)
- Head up to **48 m**

APPLICATION LIMITS

- Manometric suction lift up to **9 m** (HS)
- Liquid temperature between **-10 °C** and **+40 °C**
- Ambient temperature up to **+40 °C**
- Max. working pressure **6 bar**
- Continuous service **S1**

CONSTRUCTION AND SAFETY STANDARDS

EN 60335-1
IEC 60335-1
CEI 61-150

EN 60034-1
IEC 60034-1
CEI 2-3



CERTIFICATIONS

Company with management system
certified DNV ISO 9001: QUALITY



INSTALLATION AND USE

Suitable for use with clean water and with liquids that are not chemically aggressive towards the materials from which the pump is made. The self-priming JSW pumps are designed to pump water even in cases where air is present. Because of their reliability and the fact that they are easy to use, they are recommended for use in domestic applications such as the distribution of water in combination with small or medium sized pressure tanks, and for the irrigation of gardens and orchards, etc. Installation needs to be undertaken in well ventilated closed areas or anyway protected from bad weather.

PATENTS - TRADE MARKS - MODELS

- JSW® Registered Trade Mark n. 013073135
- Registered EU Design n. 002218610
- European Patent n. 1 510 696

OPTIONS AVAILABLE ON REQUEST

- Pumps with technopolymer impeller
- Other voltages or 60 Hz frequency

CHARACTERISTIC CURVES AND PERFORMANCE DATA

50 Hz n= 2900 min⁻¹ HS= 0 m

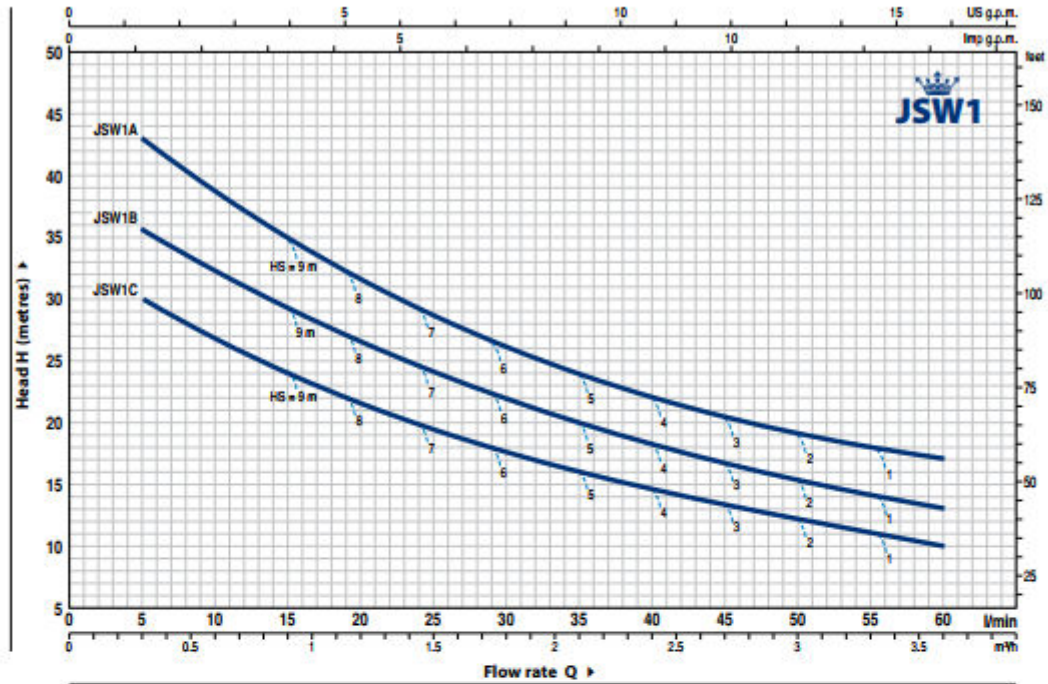

MODEL		POWER (P ₂)		Q	Flow rate										
Single-phase	Three-phase	kW	HP ▲		IE2	0	0.3	0.6	1.2	1.5	1.8	2.4	2.7	3.0	3.6
JSWm 1C	JSW 1C	0.37	0.50	H metres	0	5	10	20	25	30	40	45	50	60	
JSWm 1B	JSW 1B	0.48	0.65		IE3	34	30	27	21.7	19.5	17.7	14.7	13.4	12.2	10
JSWm 1A	JSW 1A	0.55	0.75		39.5	35.5	32.4	26.6	24.2	22	18.3	16.7	15.3	13	
					48	43	39	31.5	28.5	26	22	20.5	19	17	

Q = Flow rate H = Total manometric head HS = Suction height



Tolerance of characteristic curves in compliance with EN ISO 9906 Grade 3B.

▲ Three-phase motor efficiency class (IEC 60034-30-1)

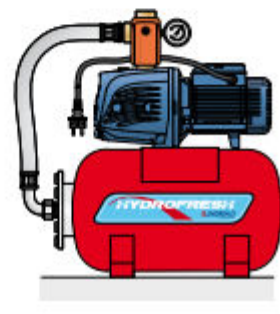
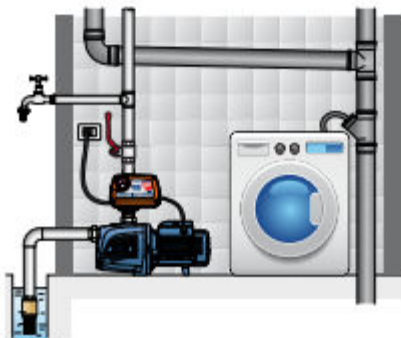
TYPICAL INSTALLATION



JSW1

POS.	COMPONENT	CONSTRUCTION CHARACTERISTICS														
1	PUMP BODY	Cast iron with an Epoxy Electro Coating treatment, with threaded ports in compliance with ISO 228/1														
2	BODY BACKPLATE	Stainless steel AISI 304														
3	NOZZLE ASSEMBLY	Noryl														
4	IMPELLER	Stainless steel AISI 304														
5	MOTOR SHAFT	Stainless steel AISI 431														
6	MECHANICAL SEAL	<table border="1"> <thead> <tr> <th>Seal Model</th> <th>Shaft Diameter</th> <th>Stationary ring</th> <th>Materials Rotational ring</th> <th>Elastomer</th> </tr> </thead> <tbody> <tr> <td>AR-12</td> <td>Ø 12 mm</td> <td>Ceramic</td> <td>Graphite</td> <td>NBR</td> </tr> </tbody> </table>	Seal Model	Shaft Diameter	Stationary ring	Materials Rotational ring	Elastomer	AR-12	Ø 12 mm	Ceramic	Graphite	NBR				
Seal Model	Shaft Diameter	Stationary ring	Materials Rotational ring	Elastomer												
AR-12	Ø 12 mm	Ceramic	Graphite	NBR												
7	BEARINGS	6201 ZZ / 6201 ZZ														
8	CAPACITOR	EN 60252-1/A1  														
9	ELECTRIC MOTOR	<p>JSWm: single-phase 230 V - 50 Hz with thermal overload protector incorporated into the winding. JSW: three-phase 230/400 V - 50 Hz.</p> <p>⇒ The three-phase pumps are fitted with high performance motors up to P2=0.48 kW in class IE2 and from P2=0.55 kW in class IE3 (IEC 60034-30-1)</p> <p>– Insulation: class F – Protection: IP X4</p>														

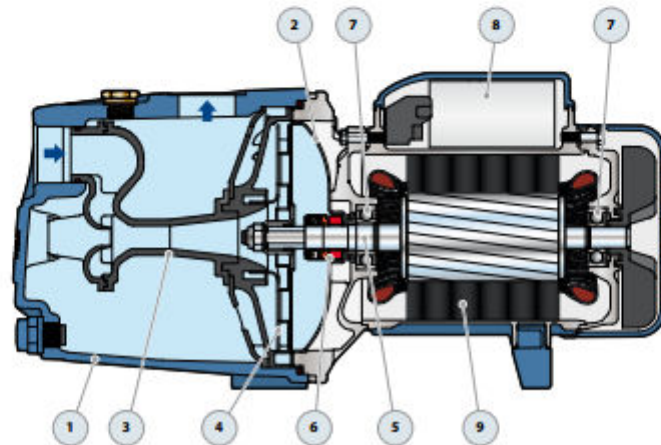

DIMENSIONS AND WEIGHT

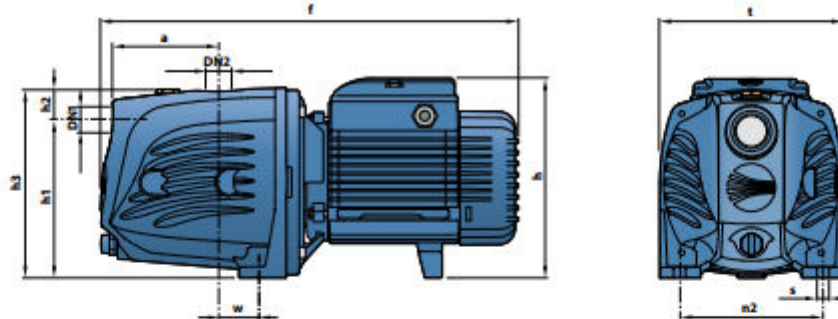

MODEL		PORTS		DIMENSIONS mm										kg	
Single-phase	Three-phase	DN1	DN2	a	f	h	h1	h2	h3	t	n2	w	s	1~	3~
JSWm 1C	JSW 1C	1"	1"	94	357	171	127	35	162	158	124	24	10	9.7	9.7
JSWm 1B	JSW 1B													9.8	9.8
JSWm 1A	JSW 1A													10.7	9.8

ABSORPTION

MODEL	VOLTAGE		
Single-phase	230 V	240 V	110 V
JSWm 1C	2.5 A	2.4 A	5.0 A
JSWm 1B	3.0 A	3.0 A	6.0 A
JSWm 1A	3.6 A	3.3 A	7.2 A

MODEL	VOLTAGE					
Three-phase	230 V	400 V	690 V	240 V	415 V	720 V
JSW 1C	1.7 A	1.0 A	0.6 A	1.7 A	1.0 A	0.6 A
JSW 1B	2.3 A	1.3 A	0.8 A	2.1 A	1.2 A	0.7 A
JSW 1A	2.8 A	1.6 A	0.9 A	2.6 A	1.5 A	0.9 A

CAPACITORS

MODEL	CAPACITANCE	
Single-phase	230 V or 240 V	110 V
JSWm 1C	10 μ F - 450 VL	25 μ F - 450 VL
JSWm 1B	12.5 μ F - 450 VL	25 μ F - 450 VL
JSWm 1A	14 μ F - 450 VL	25 μ F - 450 VL

PALLETIZATION

MODEL		GROUPAGE	CONTAINER
Single-phase	Three-phase	n. pumps	n. pumps
JSWm 1C	JSW 1C	98	140
JSWm 1B	JSW 1B	98	140
JSWm 1A	JSW 1A	98	140



Self-priming "JET" pumps

-  Clean water
-  Domestic use
-  Civil use



PERFORMANCE RANGE

- Flow rate up to **70 l/min** (4.2 m³/h)
- Head up to **70 m**

APPLICATION LIMITS

- Manometric suction lift up to **9 m** (HS)
- Liquid temperature between **-10 °C** and **+40 °C**
- Ambient temperature up to **+40 °C**
- Max. working pressure **7 bar**
- Continuous service **S1**

CONSTRUCTION AND SAFETY STANDARDS

EN 60335-1 EN 60034-1
IEC 60335-1 IEC 60034-1
CEI 61-150 CEI 2-3



CERTIFICATIONS

Company with management system
certified DNV ISO 9001: QUALITY



INSTALLATION AND USE

Suitable for use with clean water and liquids that are not chemically aggressive towards the materials from which the pump is made. The self-priming **JSW** pumps are designed to pump water even in cases where air is present. Because of their reliability and the fact that they are easy to use, they are recommended for use in domestic applications such as the distribution of water in combination with small or medium sized pressure tanks, and for the irrigation of gardens and orchards, etc. Installation needs to be undertaken in well ventilated closed areas or anyway protected from bad weather.

PATENTS - TRADE MARKS - MODELS

- **JSW**® Registered Trade Mark n. 013073135
- Registered EU Design n. 002218610
- European Patent n. 1 510 696

OPTIONS AVAILABLE ON REQUEST

- Other voltages or 60 Hz frequency

CHARACTERISTIC CURVES AND PERFORMANCE DATA

50 Hz n = 2900 min⁻¹ HS = 0 m

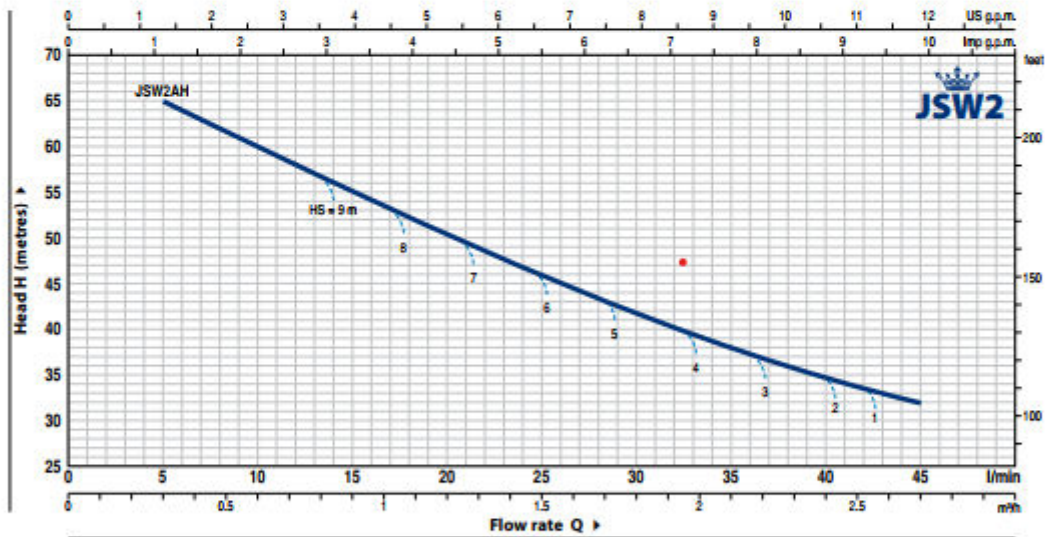
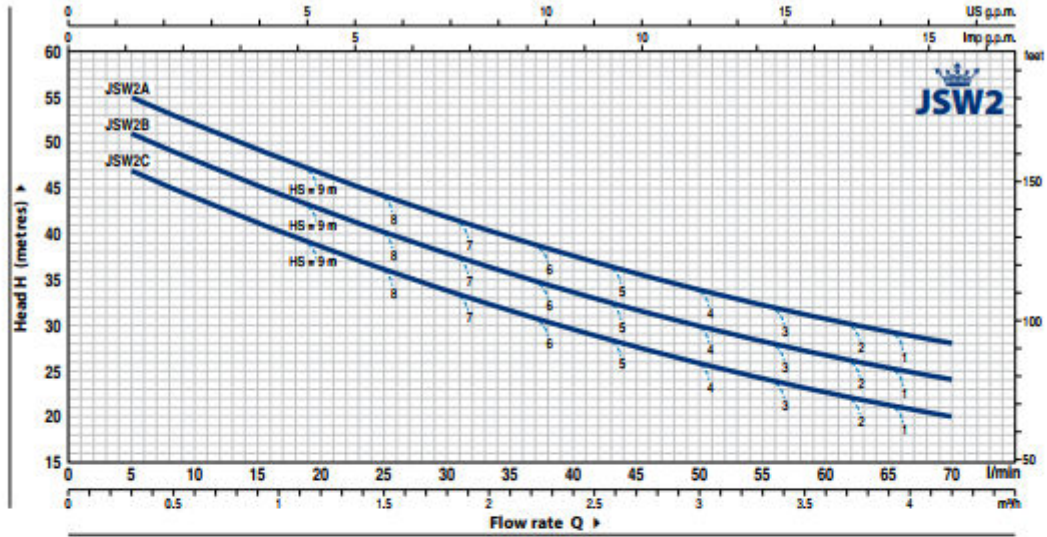



MODEL		POWER (P ₂)		▲	Q										
Single-phase	Three-phase	kW	HP			m ³ /h	0	0.3	0.6	1.2	1.8	2.4	2.7	3.0	3.6
JSWm 2C	JSW 2C	0.75	1	IE3	H metres	0	5	10	20	30	40	45	50	60	70
JSWm 2B	JSW 2B	0.90	1.25			50	47	44	38.5	34	29.5	27.5	26	22.5	20
JSWm 2A	JSW 2A	1.1	1.5			54	51	48	42.5	38	33.5	31.5	30	26.5	24
JSWm 2AH	JSW 2AH	1.1	1.5			58	55	52	46.5	42	37.5	35.5	34	31	28
						70	65	60	50.5	41.5	34.5	32			

Q = Flow rate H = Total manometric head HS = Suction height

Tolerance of characteristic curves in compliance with EN ISO 9906 Grade 3B.

▲ Three-phase motor efficiency class (IEC 60034-30-1)

JSW2

POS.	COMPONENT	CONSTRUCTION CHARACTERISTICS				
1	PUMP BODY	Cast iron, complete with threaded ports in compliance with ISO 228/1				
2	BODY BACKPLATE	Stainless steel AISI 304				
3	NOZZLE ASSEMBLY	Noryl				
4	IMPELLER	Stainless steel AISI 304 (Technopolymer for JSW X)				
5	MOTOR SHAFT	Stainless steel AISI 431				
6	MECHANICAL SEAL	<i>Seal Model</i> AR-14	<i>Shaft Diameter</i> Ø 14 mm	<i>Stationary ring</i> Ceramic	<i>Materials</i> <i>Rotational ring</i> Graphite	<i>Elastomer</i> NBR
7	BEARINGS	6203 ZZ / 6203 ZZ				
8	CAPACITOR	EN 60252-1/A1  				
9	ELECTRIC MOTOR	JSWm: single-phase 230 V - 50 Hz with thermal overload protector incorporated into the winding. JSW: three-phase 230/400 V - 50 Hz. ⇒ The three-phase pumps are fitted with high performance motors in class IE3 (IEC 60034-30-1) – Insulation: class F – Protection: IP X4				

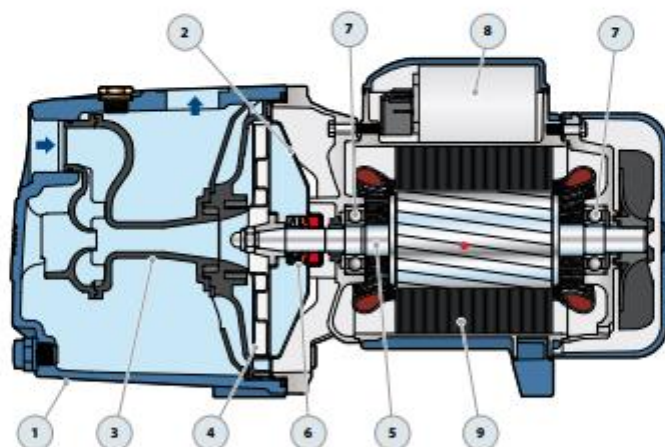

TYPICAL INSTALLATION



DIMENSIONS AND WEIGHT

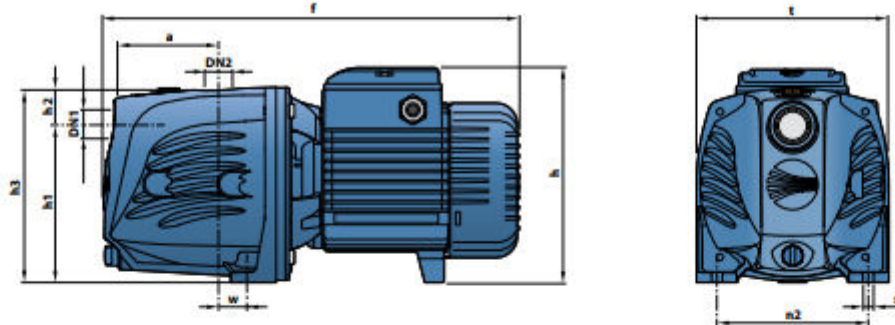

MODEL		PORTS		DIMENSIONS mm										kg	
Single-phase	Three-phase	DN1	DN2	a	f	h	h1	h2	h3	t	n2	w	s	1~	3~
JSWm 2C	JSW 2C	1"	1"	96	389	200*	147	33	180	180	142	22	10	13.4	13.4
JSWm 2B	JSW 2B													14.0	14.0
JSWm 2A	JSW 2A													15.0	14.0
JSWm 2AH	JSW 2AH													14.2	14.3
JSWm 2CX	JSW 2CX	1"	1"	96	389	200*	147	33	180	180	142	22	10	13.1	12.9
JSWm 2BX	JSW 2BX													14.0	13.6
JSWm 2AX	JSW 2AX													14.6	15.0

(*) h=220 mm for single-phase versions at 110 V

ABSORPTION

MODEL	VOLTAGE		
	230 V	240 V	110 V
Single-phase			
JSWm 2C	4.7 A	4.5 A	9.4 A
JSWm 2B	5.8 A	5.3 A	11.6 A
JSWm 2A	6.0 A	5.5 A	12.0 A
JSWm 2AH	6.0 A	5.8 A	12.0 A
JSWm 2CX	4.7 A	4.5 A	9.4 A
JSWm 2BX	5.8 A	5.3 A	11.6 A
JSWm 2AX	6.0 A	5.5 A	12.0 A

MODEL	VOLTAGE					
	230 V	400 V	690 V	240 V	415 V	720 V
Three-phase						
JSW 2C	3.5 A	2.0 A	1.2 A	3.4 A	1.9 A	1.1 A
JSW 2B	4.6 A	2.7 A	1.6 A	4.5 A	2.6 A	1.5 A
JSW 2A	5.1 A	3.0 A	1.7 A	4.9 A	2.8 A	1.7 A
JSW 2AH	5.1 A	3.0 A	1.7 A	4.9 A	2.8 A	1.7 A
JSW 2CX	3.5 A	2.0 A	1.2 A	3.4 A	1.9 A	1.1 A
JSW 2BX	4.6 A	2.7 A	1.6 A	4.5 A	2.6 A	1.5 A
JSW 2AX	5.1 A	3.0 A	1.7 A	4.9 A	2.8 A	1.7 A

CAPACITORS

MODEL	CAPACITANCE	
	230 V or 240 V	110 V
Single-phase		
JSWm 2C	20 μ F - 450 VL	60 μ F - 300 VL
JSWm 2B	25 μ F - 450 VL	60 μ F - 300 VL
JSWm 2A	25 μ F - 450 VL	60 μ F - 300 VL
JSWm 2AH	25 μ F - 450 VL	60 μ F - 300 VL
JSWm 2CX	20 μ F - 450 VL	60 μ F - 300 VL
JSWm 2BX	25 μ F - 450 VL	60 μ F - 300 VL
JSWm 2AX	25 μ F - 450 VL	60 μ F - 300 VL

PALLETIZATION

MODEL		GROUPAGE	CONTAINER
Single-phase	Three-phase	n. pumps	n. pumps
JSWm 2C	JSW 2C	72	96
JSWm 2B	JSW 2B	72	96
JSWm 2A	JSW 2A	72	96
JSWm 2AH	JSW 2AH	72	96
JSWm 2CX	JSW 2CX	72	96
JSWm 2BX	JSW 2BX	72	96
JSWm 2AX	JSW 2AX	72	96



Self-priming "JET" pumps

-  Clean water
-  Domestic use
-  Civil use
-  Industrial use



PERFORMANCE RANGE

- Flow rate up to 160 l/min (9.6 m³/h)
- Head up to 97 m

APPLICATION LIMITS

- Manometric suction lift up to 9 m (HS)
- Liquid temperature between -10 °C and +40 °C
- Ambient temperature up to +40 °C
- Max. working pressure 10 bar
- Continuous service S1

CONSTRUCTION AND SAFETY STANDARDS

EN 60335-1 EN 60034-1
IEC 60335-1 IEC 60034-1
CEI 61-150 CEI 2-3



CERTIFICATIONS

Company with management system certified DNV
ISO 9001: QUALITY



INSTALLATION AND USE

Suitable for use with clean water and with liquids that are not chemically aggressive towards the materials from which the pump is made. The self-priming JSW pumps are designed to pump water even in cases where air is present. Because of their reliability and the fact that they are easy to use, they are recommended for use in domestic, civil and industrial applications such as the distribution of water in combination with pressure tanks, and for the irrigation of gardens and orchards, etc. Installation needs to be undertaken in well ventilated closed areas or anyway protected from bad weather.

PATENTS - TRADE MARKS - MODELS

- Registered Trade Mark n. 013073135 JSW*
- Registered EU Design n. 002218610

OPTIONS AVAILABLE ON REQUEST

- Other voltages or 60 Hz frequency
- IPX5 protection

CHARACTERISTIC CURVES AND PERFORMANCE DATA

50 Hz n=2900 min⁻¹ HS=0 m

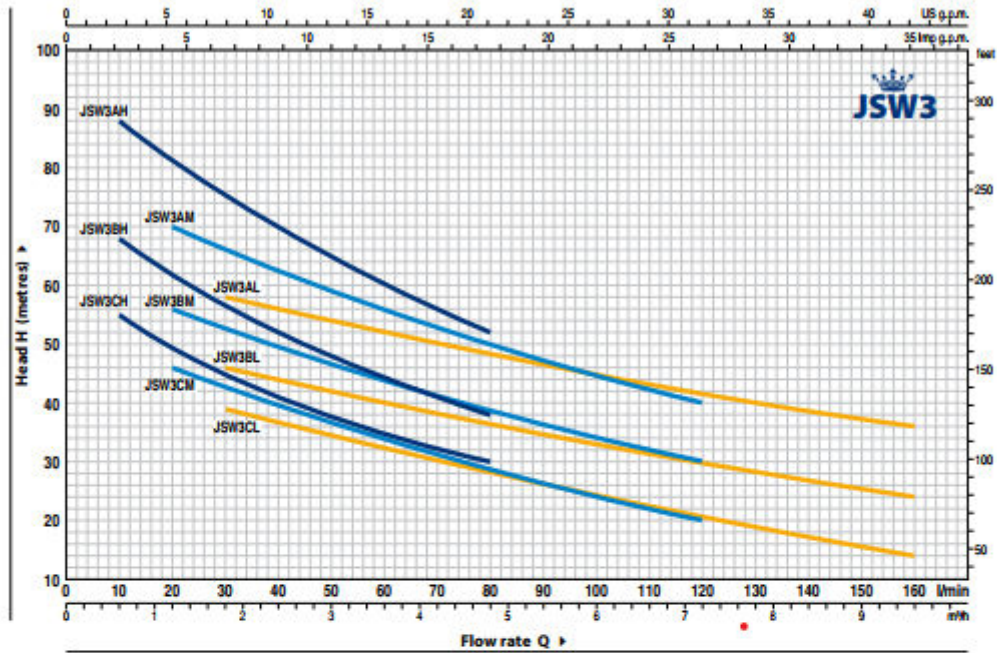

MODEL		POWER (P ₂)		▲	Q	Flow rate (m³/h)														
Single-phase	Three-phase	kW	HP			0	0.6	1.2	1.8	2.4	3.0	3.6	4.2	4.8	6.0	7.2	8.4	9.6		
JSWm 3CH	JSW 3CH	1.1	1.5	IE3	l/min	0	10	20	30	40	50	60	70	80	100	120	140	160		
JSWm 3BH	JSW 3BH	1.5	2		H metres	62	55	49	45	41	38	35	32	30						
JSWm 3AH	JSW 3AH	2.2	3		73	68	62	56.5	52	48	44	41	38							
JSWm 3CM	JSW 3CM	1.1	1.5		97	88	81	75	70	65	60.5	56	52							
JSWm 3BM	JSW 3BM	1.5	2		54	-	46	43	39.5	36.5	34	31	28.5	24	20					
JSWm 3AM	JSW 3AM	2.2	3		63	-	56	53	49.5	47.5	44	41	39	34	30					
JSWm 3AL	JSW 3AL	2.2	3		78	-	70	66	62	59	56	53	50	45	40					
JSWm 3CL	JSW 3CL	1.1	1.5		44	-	-	39	37	34	32	30	28	24	21	17	14			
JSWm 3BL	JSW 3BL	1.5	2		51	-	-	46	44	42	40	38	36	33	30	27	24			
JSWm 3AL	JSW 3AL	2.2	3		64	-	-	58	56	54	52	50	48	45	41.5	38.5	36			

Q = Flow rate H = Total manometric head HS = Suction height

Tolerance of characteristic curves in compliance with EN ISO 9906 Grade 3B.

▲ Three-phase motor efficiency class (IEC 60034-30-1)

STANDARD INSTALLATION

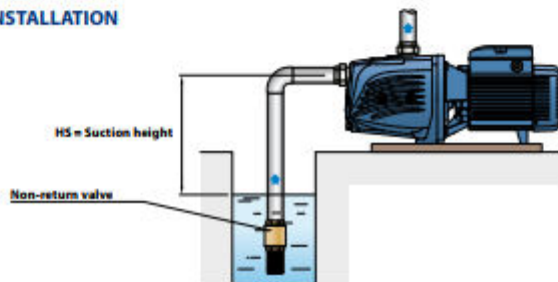

JSW3

POS.	COMPONENT	CONSTRUCTION CHARACTERISTICS				
1	PUMP BODY	Cast iron with an Epoxy Electro Coating treatment, with threaded ports in compliance with ISO 228/1				
2	BODY BACKPLATE	Cast iron				
3	NOZZLE ASSEMBLY	Noryl FE1520PW				
4	IMPELLER	Stainless steel AISI 304				
5	MOTOR SHAFT	Stainless steel AISI 431				
6	MECHANICAL SEAL	<i>Seal</i>	<i>Shaft</i>	<i>Materials</i>		
		<i>Model</i>	<i>Diameter</i>	<i>Stationary ring</i>	<i>Rotational ring</i>	<i>Elastomer</i>
		FN-18	Ø 18 mm	Graphite	Ceramic	NBR
7	BEARINGS	6204 ZZ / 6204 ZZ				
8	CAPACITOR	<i>Pump</i>	<i>Capacitance</i>			
		<i>Single-phase</i>	<i>(230 V or 240 V)</i>	<i>(110 V)</i>		
		JSWm 3C	31.5 µF - 450 VL	60 µF - 250 VL		
		JSWm 3B	45 µF - 450 VL	80 µF - 250 VL		
		JSWm 3A	50 µF - 450 VL	-		
9	ELECTRIC MOTOR	JSWm: single-phase 230 V - 50 Hz with thermal overload protector incorporated into the winding. JSW: three-phase 230/400 V - 50 Hz. ⇒ The three-phase pumps are fitted with high performance motors in class IE3 (IEC 60034-30-1) – Insulation: class F – Protection: IP X4				

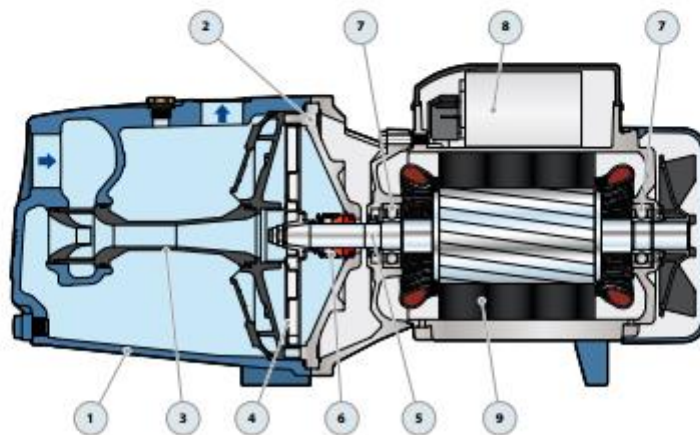

DIMENSIONS AND WEIGHT

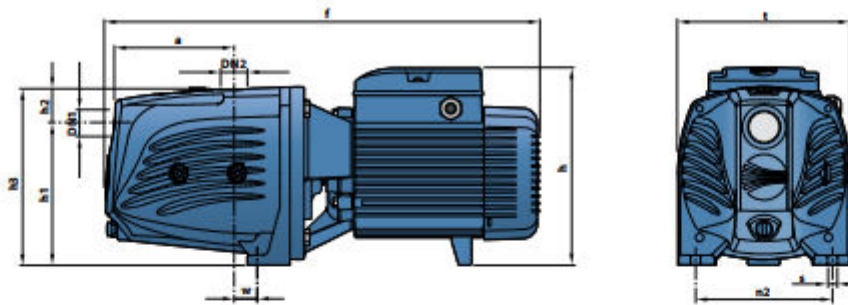

MODEL		PORTS		DIMENSIONS mm										kg	
Single-phase	Three-phase	DN1	DN2	a	f	h	h1	h2	h3	t	n2	w	s	1~	3~
JSWm 3CH	JSW 3CH	1½"	1"	143	522	240	165	39	204	206	164	30	11	24.2	28.2
JSWm 3BH	JSW 3BH				542									25.5	25.4
JSWm 3AH	JSW 3AH				542									28.2	28.0
JSWm 3CM	JSW 3CM				522									24.4	24.4
JSWm 3BM	JSW 3BM				542									25.6	25.5
JSWm 3AM	JSW 3AM				542									28.0	28.2
JSWm 3CL	JSW 3CL				522									24.4	24.3
JSWm 3BL	JSW 3BL				542									25.6	25.5
JSWm 3AL	JSW 3AL				542									28.2	28.2

ABSORPTION

MODEL	VOLTAGE		
	230 V	240 V	110 V
JSWm 3CH	8.1 A	7.8 A	16.2 A
JSWm 3BH	9.5 A	9.2 A	19.0 A
JSWm 3AH	12.7 A	12.4 A	-
JSWm 3CM	8.1 A	7.8 A	16.2 A
JSWm 3BM	9.7 A	9.4 A	19.4 A
JSWm 3AM	13.0 A	12.5 A	-
JSWm 3CL	8.1 A	7.8 A	16.2 A
JSWm 3BL	10.1 A	9.8 A	20.2 A
JSWm 3AL	13.6 A	13.1 A	-

MODEL	VOLTAGE					
	230 V	400 V	690 V	240 V	415 V	720 V
JSW 3CH	5.2 A	3.0 A	1.7 A	5.0 A	2.9 A	1.7 A
JSW 3BH	6.0 A	3.5 A	2.0 A	5.8 A	3.4 A	1.9 A
JSW 3AH	8.8 A	5.1 A	2.9 A	8.5 A	4.9 A	2.8 A
JSW 3CM	5.2 A	3.0 A	1.7 A	5.0 A	2.9 A	1.7 A
JSW 3BM	6.0 A	3.5 A	2.0 A	5.8 A	3.4 A	1.9 A
JSW 3AM	9.0 A	5.2 A	3.0 A	8.6 A	5.0 A	2.9 A
JSW 3CL	5.2 A	3.0 A	1.7 A	5.0 A	2.9 A	1.7 A
JSW 3BL	6.4 A	3.7 A	2.1 A	6.1 A	3.6 A	2.0 A
JSW 3AL	9.3 A	5.4 A	3.1 A	9.0 A	5.2 A	3.0 A

PALLETIZATION

MODEL		GROUPAGE	CONTAINER
Single-phase	Three-phase	n. pumps	n. pumps
JSWm 3CH	JSW 3CH	35	49
JSWm 3BH	JSW 3BH	35	49
JSWm 3AH	JSW 3AH	35	49
JSWm 3CM	JSW 3CM	35	49
JSWm 3BM	JSW 3BM	35	49
JSWm 3AM	JSW 3AM	35	49
JSWm 3CL	JSW 3CL	35	49
JSWm 3BL	JSW 3BL	35	49
JSWm 3AL	JSW 3AL	35	49