

Centrifugal pumps with open impeller

WITH CAST IRON PUMP BODY

 Clean water

 Domestic use

 Civil use

 Agricultural use

 Industrial use

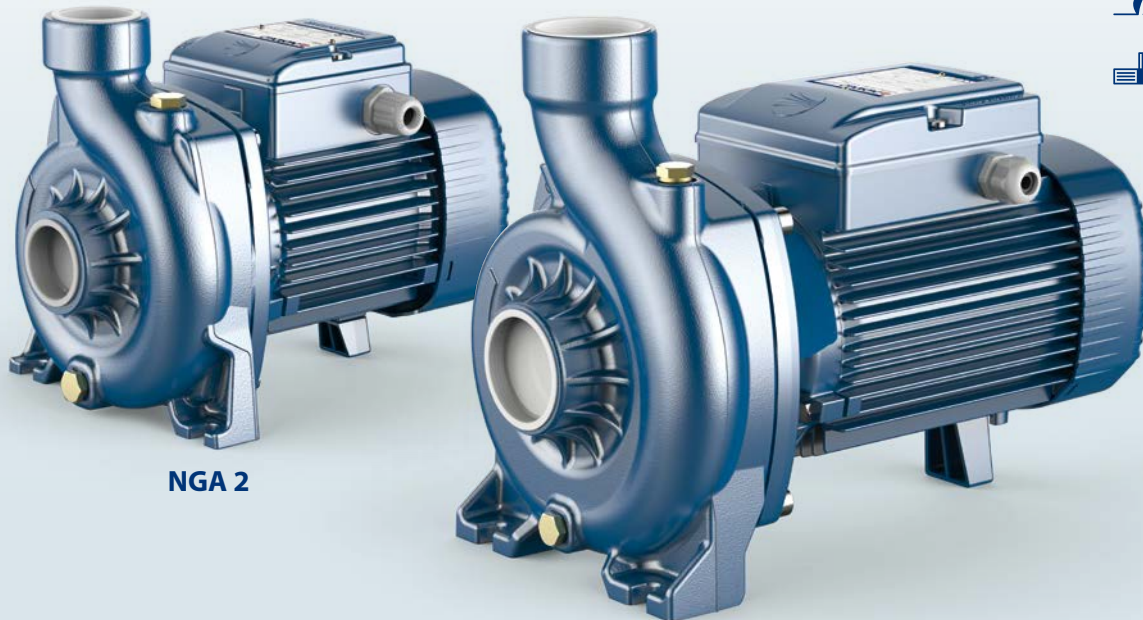

NGA 2

NGA 3

PERFORMANCE RANGE

- Flow rate up to **900 l/min** (54 m³/h)
- Head up to **20.5 m**

APPLICATION LIMITS

- Manometric suction lift up to **7 m**
- Liquid temperature between **-10 °C** and **+90 °C**
- Ambient temperature between **-10 °C** and **+40 °C**
- Max. working pressure:
 - **6 bar** for NGA1 and NGA2
 - **10 bar** for NGA3
- Passage of suspended solids up to:
 - **Ø 12 mm** for NGA1 and NGA2
 - **Ø 20 mm** for NGA3
- Continuous service **S1**

CONSTRUCTION AND SAFETY STANDARDS

EN 60335-1
IEC 60335-1
CEI 61-150

EN 60034-1
IEC 60034-1
CEI 2-3



EU REGULATION N. 547/2012

CERTIFICATIONS

Company with management system certified DNV ISO 9001: QUALITY



INSTALLATION AND USE

Suitable for use with liquids that are not chemically aggressive towards the materials from which the pump is made.

The open impeller design allows **liquids containing relatively high levels of impurities** to be pumped without the risk of the impeller clogging.

NGA pumps are particularly suitable for pumping liquids that are not completely clean, guaranteeing the passage of solids up to 20 mm and therefore applications such as: transfers from canals, rivers, reservoirs, tanks, etc.

Installation needs to be undertaken in well ventilated closed areas or anyway protected from bad weather.

OPTIONS AVAILABLE ON REQUEST

- Special mechanical seal
- Pump body with threaded ports NPT ANSI B 1.20.1
- Other voltages or 60 Hz frequency
- On request up to **110 °C**
- **IP X5 Protection for NGA 3**
- Supply of ISO 228/1 flanges for intake and delivery ports in AISI 316 stainless steel



CHARACTERISTIC CURVES AND PERFORMANCE DATA

50 Hz n = 2900 min⁻¹ HS = 0 m

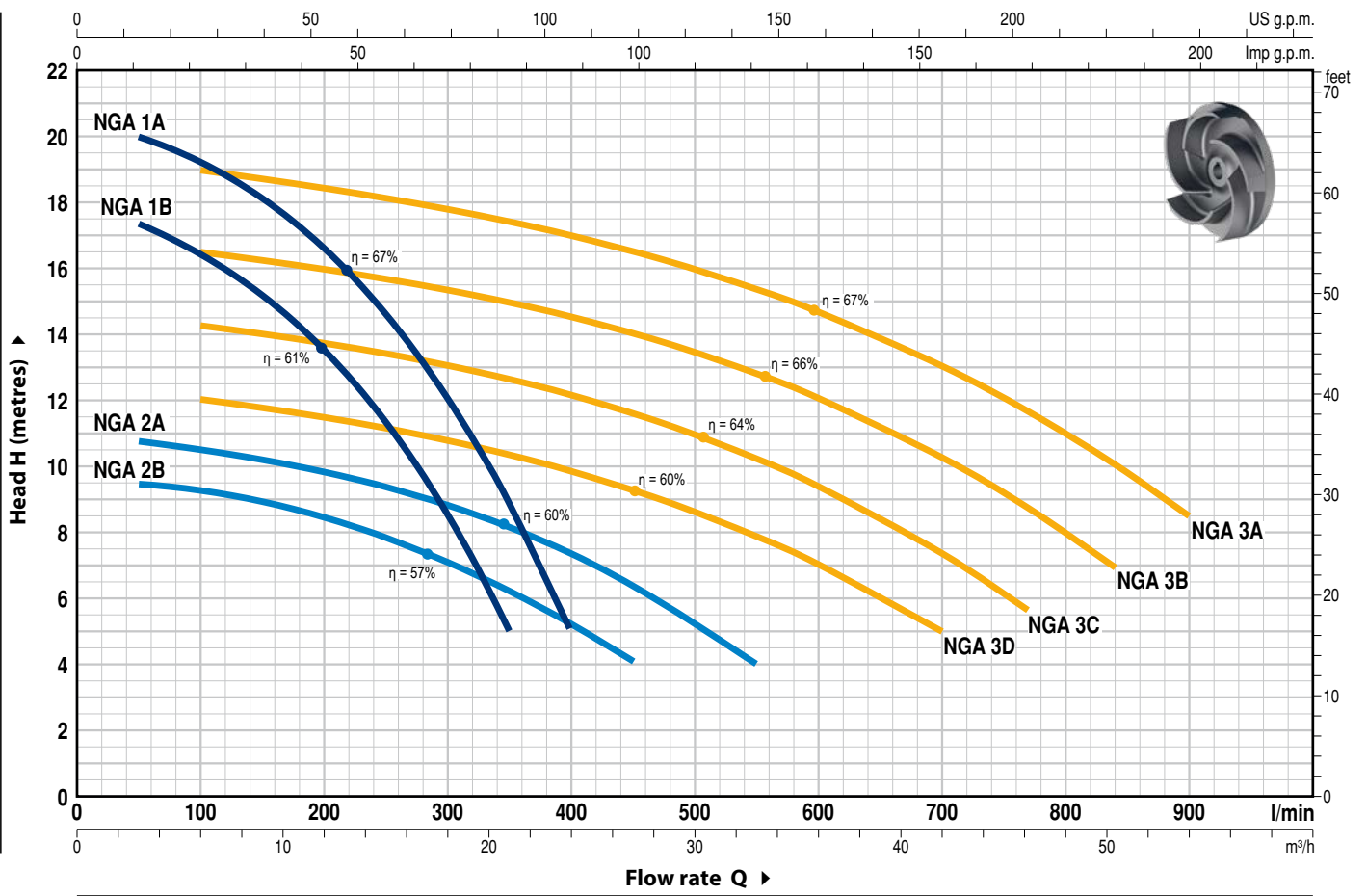

MODEL		POWER (P ₂)			Q	Flow rate												
Single-phase	Three-phase	kW	HP	▲		0	3	6	9	12	15	18	21	24				
NGAm 1B	NGA 1B	0.55	0.75	IE3	0	50	100	150	200	250	300	350	400					
NGAm 1A	NGA 1A	0.75	1		18	17.4	16.4	15.2	13.5	11.3	8.7	5						
					H metres	20.5	20	19.3	18.1	16.6	14.7	12.1	9	5				

MODEL		POWER (P ₂)			Q	Flow rate														
Single-phase	Three-phase	kW	HP	▲		0	3	6	12	18	24	27	33	42	46.2	50.4	54			
NGAm 2B	NGA 2B	0.55	0.75	IE3	0	50	100	200	300	400	450	550	700	770	840	900				
NGAm 2A	NGA 2A	0.75	1		9.5	9.4	9.3	8.4	7	5.2	4									
NGAm 3D	NGA 3D	1.1	1.5		11	10.8	10.5	9.8	8.8	7.4	6.4	4								
NGAm 3C	NGA 3C	1.5	2		12.5	-	12	11.5	10.8	9.8	9.3	7.8	5							
NGAm 3B	NGA 3B	1.8	2.5		14.8	-	14.4	13.8	13.1	12.2	11.7	10.3	7.4	5.7						
NGAm 3A	NGA 3A	2.2	3		17	-	16.5	16	15.3	14.5	14	12.8	10.3	8.8	7					
					H metres	19.5	-	19	18.4	17.8	17	16.5	15.4	13	11.5	10	8.5			

Q = Flow rate H = Total manometric head HS = Suction height

Tolerance of characteristic curves in compliance with EN ISO 9906 Grade 3B.

▲ Three-phase motor efficiency class (IEC 60034-30-1)

POS. COMPONENT CONSTRUCTION CHARACTERISTICS

1	PUMP BODY	Cast iron JL 250 with an Epoxy Electro Coating treatment, with threaded ports in compliance wit ISO 228/1						
2	BODY BACKPLATE	Cast iron JL 200 for NGA3 Stainless steel AISI 304 for NGA1 and NGA2						
3	IMPELLER	Open impeller in Cast iron JL 250 with an Epoxy Electro Coating treatment						
4	MOTOR SHAFT	Stainless steel AISI 431						
5	MECHANICAL SEAL	<i>Pump</i>	<i>Seal</i>	<i>Shaft</i>	<i>Materials</i>			
		<i>Model</i>	<i>Model</i>	<i>Diametro</i>	<i>Stationary ring</i>	<i>Rotational ring</i>	<i>Elastomer</i>	<i>Spring</i>
		NGA1	AR-14	Ø 14 mm	Ceramic	Graphite	NBR	AISI 304
		NGA2						
		NGA3	FN-18	Ø 18 mm	Graphite	Ceramic	NBR	AISI 316
6	BEARINGS	<i>Pump</i>	<i>Model</i>					
		NGA1	6203 ZZ / 6203 ZZ					
		NGA2	6203 ZZ / 6203 ZZ					
		NGA3	6204 ZZ / 6204 ZZ					
7	ELECTRIC MOTOR	NGAm: single-phase 230 V - 50 Hz with thermal overload protector incorporated into the winding. NGA: three-phase 230/400 V - 50 Hz. ⇒ The three-phase pumps are fitted with high performance motors in class IE3 (IEC 60034-30-1) – Insulation: class F – Protection: IP X4						

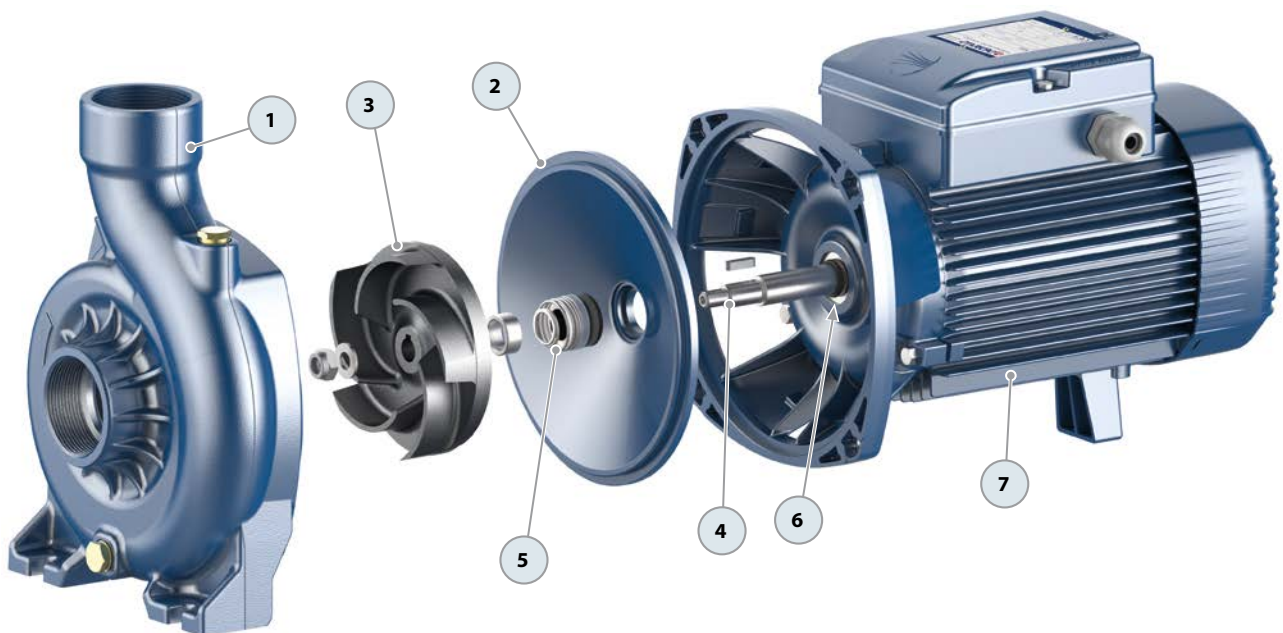

DIMENSIONS AND WEIGHT

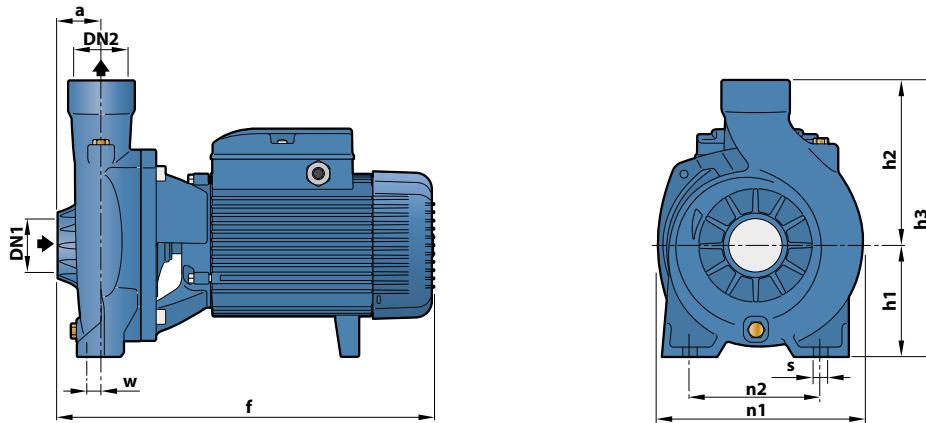

WITH THREADED PORTS

MODEL		PORTS		DIMENSIONS mm								kg		
Single-phase	Three-phase	DN1	DN2	a	f	h1	h2	h3	n1	n2	w	s	1~	3~
NGAm 1B	NGA 1B	1½"	1½"	40	299	92	135	227	190	160	6	11	12.5	12.5
NGAm 1A	NGA 1A			32									12.7	12.7
NGAm 2B	NGA 2B			32									12.9	12.9
NGAm 2A	NGA 2A			32									13.1	13.1
NGAm 3D	NGA 3D	2"	2"	48	387	120	178	298	217	140	18	11.5	21.4	22.2
NGAm 3C	NGA 3C			407									23.1	23.1
NGAm 3B	NGA 3B			407									25.7	25.7
NGAm 3A	NGA 3A			407									25.7	25.7

WITH FLANGED PORTS

MODEL		PORTS		DIMENSIONS mm				
Single-phase	Three-phase	DN1	DN2	a	f	h1	h2	h3
NGAm 1B	NGA 1B	40	40	60	334	92	156	248
NGAm 1A	NGA 1A			52				
NGAm 2B	NGA 2B			52				
NGAm 2A	NGA 2A			52				
NGAm 3D	NGA 3D	50	50	70	408	120	200	320
NGAm 3C	NGA 3C			428				
NGAm 3B	NGA 3B			428				
NGAm 3A	NGA 3A			428				

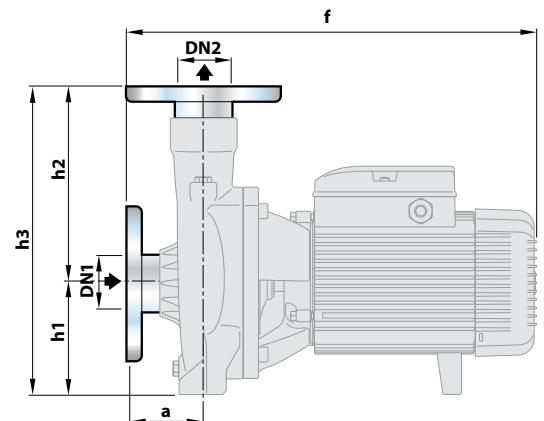

FLANGES	D	K	F	HOLES	
DN	mm	mm	mm	N°	Ø (mm)
40	150	110	78	4	18
50	165	125	99	4	18

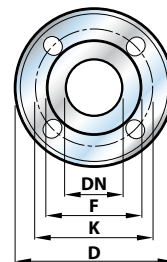

ABSORPTION AND CAPACITORS

MODEL	VOLTAGE		CAPACITANCE
	230 V	240 V	
Single-phase	230 V	240 V	(230 V or 240 V)
NGAm 1B	5.5 A	5.3 A	20 µF - 450 VL
NGAm 1A	6.0 A	5.8 A	20 µF - 450 VL
NGAm 2B	5.0 A	4.8 A	20 µF - 450 VL
NGAm 2A	5.7 A	5.5 A	20 µF - 450 VL
NGAm 3D	7.5 A	7.2 A	31.5 µF - 450 VL
NGAm 3C	9.5 A	9.1 A	45 µF - 450 VL
NGAm 3B	10.5 A	10.1 A	50 µF - 450 VL
NGAm 3A	12.5 A	12.0 A	50 µF - 450 VL

MODEL	VOLTAGE					
	230 V	400 V	690 V	240 V	415 V	720 V
Three-phase	230 V	400 V	690 V	240 V	415 V	720 V
NGA 1B	3.8 A	2.2 A	1.3 A	3.6 A	2.1 A	1.2 A
NGA 1A	4.2 A	2.4 A	1.4 A	4.0 A	2.3 A	1.3 A
NGA 2B	3.5 A	2.0 A	1.2 A	3.3 A	1.9 A	1.1 A
NGA 2A	4.0 A	2.3 A	1.3 A	3.8 A	2.2 A	1.3 A
NGA 3D	5.0 A	2.9 A	1.7 A	4.8 A	2.8 A	1.6 A
NGA 3C	6.1 A	3.5 A	2.0 A	5.8 A	3.4 A	1.9 A
NGA 3B	7.8 A	4.5 A	2.6 A	7.5 A	4.3 A	2.5 A
NGA 3A	8.3 A	4.8 A	2.8 A	8.0 A	4.6 A	2.7 A