



Submersible pumps

High flow

-  Sewage water
-  Civil use
-  Industrial use



PERFORMANCE RANGE

- Flow rate up to **5000 l/min** (300 m³/h)
- Head up to **20.8 m**

APPLICATION LIMITS

- **10 m** maximum immersion depth (with a sufficiently long power cable)
- Maximum liquid temperature **+40 °C**
- Passage of suspended solids up to **Ø 80 mm**
- To have continuous duty, the pump has not to emerge (to be out) of the water for more than **290 mm**

CONSTRUCTION AND SAFETY STANDARDS

- **10 m** long power cable

EN 60335-1
IEC 60335-1
CEI 61-150

EN 60034-1
IEC 60034-1
CEI 2-3



CERTIFICATIONS

Company with management system certified DNV
ISO 9001: QUALITY



INSTALLATION AND USE

The **VXC4** series of pumps, manufactured from heavy gauge robust cast iron, resistant to abrasion and long-lasting, are fitted with a VORTEX impeller and are therefore suitable for draining **dirty, sewage and reflux water, and water mixed with putrid mud**. They are suitable for installation in sewers, tunnels, excavations, canals, underground car parks, etc.

PATENTS - TRADE MARKS - MODELS

- Registered EU Design n. 003863158-0003

OPTIONS AVAILABLE ON REQUEST

- Other voltages or 60 Hz frequency

CHARACTERISTIC CURVES AND PERFORMANCE DATA

50 Hz n= 1450 min⁻¹

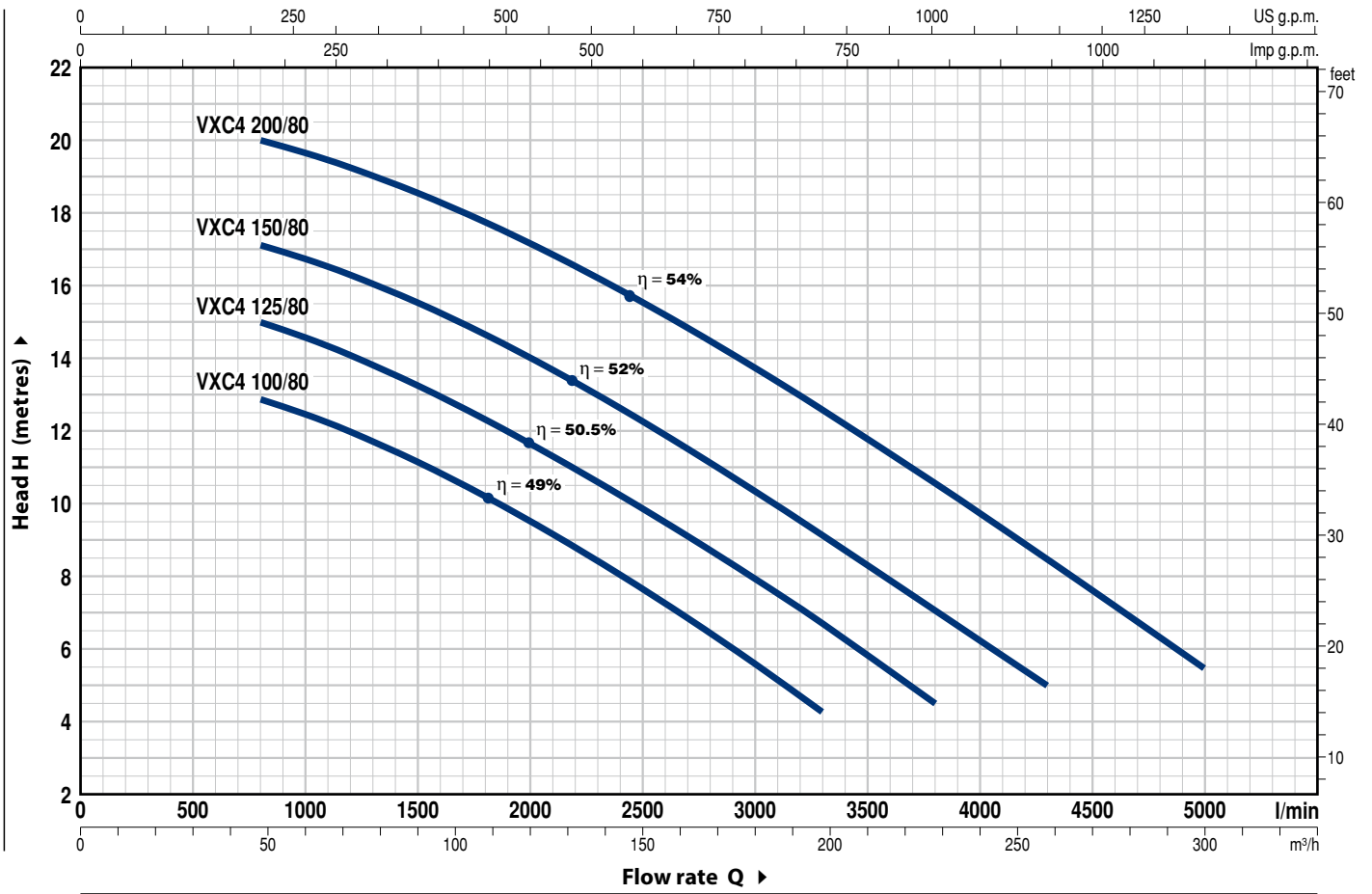

MODEL Three-phase	POWER (P ₂)		Q	Flow rate													
	kW	HP		m ³ /h	0	48	60	90	120	150	180	198	228	258	300		
			l/min	0	800	1000	1500	2000	2500	3000	3300	3800	4300	5000			
VXC4 100/80	7.5	10	H metres	13.7	12.9	12.5	11.2	9.6	7.7	5.6	4.3						
VXC4 125/80	9.2	12.5		15.8	15	14.6	13.3	11.7	9.9	7.9	6.7	4.5					
VXC4 150/80	11	15		18	17.2	16.8	15.6	14.1	12.3	10.4	9.2	7.1	5				
VXC4 200/80	15	20		20.8	20	19.7	18.6	17.2	15.6	13.8	12.6	10.6	8.5	5.5			

Q = Flow rate H = Total manometric head

Tolerance of characteristic curves in compliance with EN ISO 9906 Grade 3B.

POS. COMPONENT CONSTRUCTION CHARACTERISTICS

1 PUMP BODY	Cast iron				
2 IMPELLER	VORTEX type in cast iron				
3 MOTOR CASING	Cast iron				
4 MOTOR CASING PLATE	Cast iron				
5 MOTOR SHAFT	Stainless steel AISI 431				
6 SHAFT WITH DOUBLE MECHANICAL SEAL SEPARATED BY AN OIL CHAMBER					
<i>Seal Model</i>	<i>Shaft Diameter</i>	<i>Position</i>	<i>Stationary ring</i>	<i>Rotational ring</i>	<i>Materials Elastomer</i>
AR-35	Ø 35 mm	Motor side	Ceramic	Graphite	NBR
MG1-40	Ø 40 mm	Pump side	Silicon carbide	Silicon carbide	NBR
7 BEARINGS	6308 2RS-C3 / 3308A 2RS-C3				

8 ELECTRIC MOTOR

- three-phase 400 V - 50 Hz
with thermal overload protector incorporated into the winding
- Insulation: class F
- Protection: IP X8

9 PROBE DETECTING THE PRESENCE OF WATER IN THE OIL CHAMBER

10 POWER CABLE

"H07 RN-F" type
Standard length 10 metres

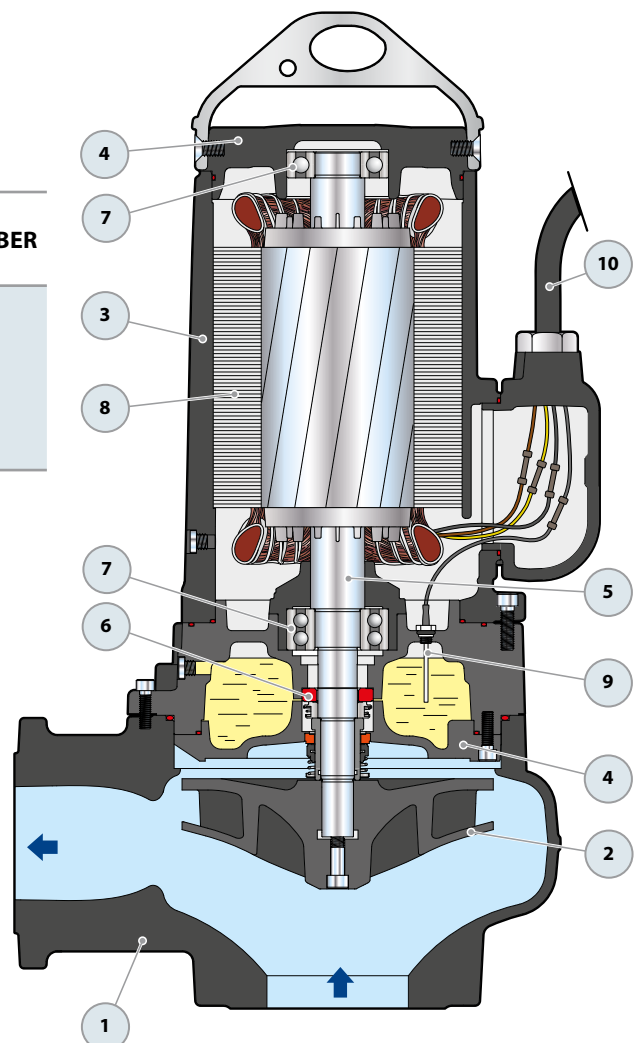

DIMENSIONS AND WEIGHT

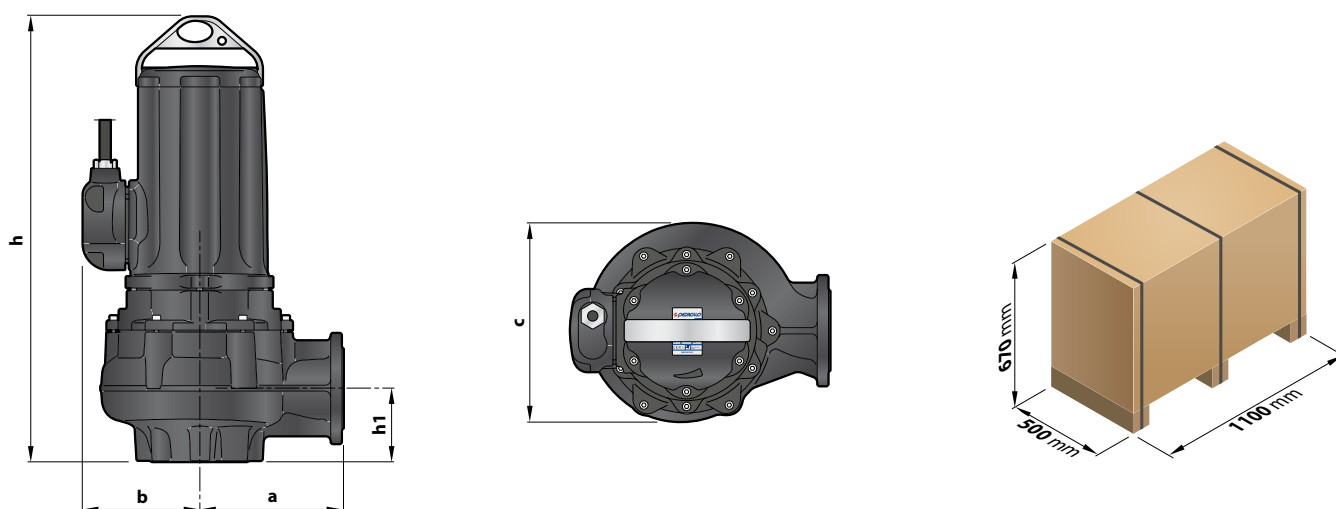

MODEL	Passage of solids	DIMENSIONS mm					kg
		a	b	c	h	h1	
Three-phase	Ø 80	285	232	395	870	145	3~
VXC4 100/80							215
VXC4 125/80							217
VXC4 150/80							227
VXC4 200/80							237

FLANGED PORT

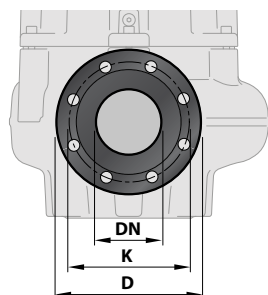

MODEL	FLANGE	K	D	HOLES	
				N°	Ø (mm)
Three-phase	DN	mm	mm		
VXC4 100/80	100 (PN10)	180	220	8	18
VXC4 125/80					
VXC4 150/80					
VXC4 200/80					

COUNTERFLANGE

(TO BE ORDERED SEPARATELY)

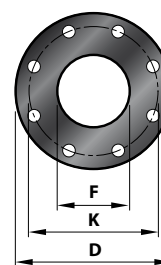

MODEL	FLANGE	F	K	D	HOLES	
					N°	Ø (mm)
Three-phase	DN		mm	mm		
VXC4 100/80	100	4"	180	220	8	18
VXC4 125/80						
VXC4 150/80						
VXC4 200/80						

ABSORPTION

MODEL	VOLTAGE
Three-phase	400 V
VXC4 100/80	16.0 A
VXC4 125/80	18.5 A
VXC4 150/80	22.5 A
VXC4 200/80	28.5 A

BASE

(TO BE ORDERED SEPARATELY)

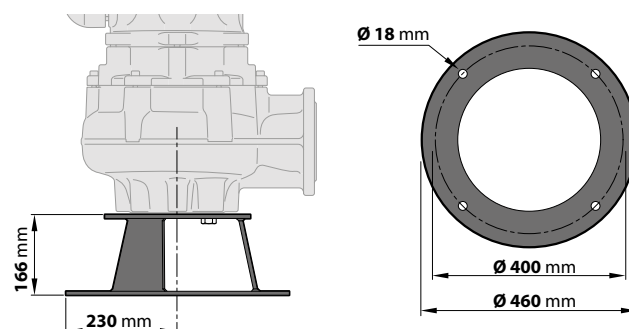

SEWAGE LIFTING SYSTEM VXC4 – MC4



VERTICAL DELIVERY VERSION WITH 2" GUIDE TUBES

For VXC4, MC4	Cod. ASSPVXC4V	DN 4"
----------------------	----------------	-------

Kit consisting of:

- footing connection complete with counterflange
- slide guide with screws and seals
- support for the guide tubes

STANDARD INSTALLATION

- | | |
|---|--|
| 1. Pump | 7. Control box |
| 2. Footing connection | 8. Stop float switch |
| 3. Guide tubes | 9. Starting float switch |
| 4. Support for the guide tubes | 10. Starting float switch auxiliary pump |
| 5. Intermediate support for the guide tubes | 11. Alarm float switch |
| 6. Lifting chain | 13. Cement base |

SLIDE GUIDE (Also to be ordered separately)

For VXC4, MC4	Cod. ASSFL100
----------------------	---------------

Complete with screws and seals

● INTERMEDIATE SUPPORT (To be ordered separately)

Cod. 859SV349INTFA	Guide tube Ø 2"
--------------------	-----------------

In order to ensure stability, insert the intermediate support every three metres of guide tube (recommended)



GUIDE TUBES (AISI 304 stainless steel)

Cod. 54SARTG006	Ø 2"
-----------------	------

Maximum length of the tube plank: 6 metres

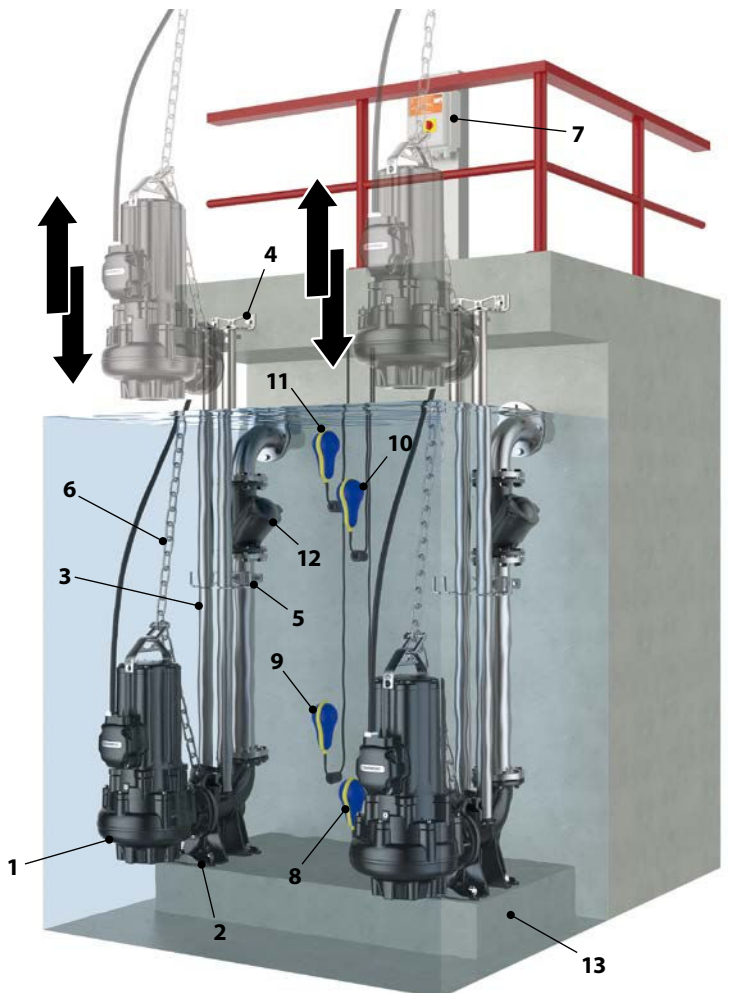

DIMENSIONS

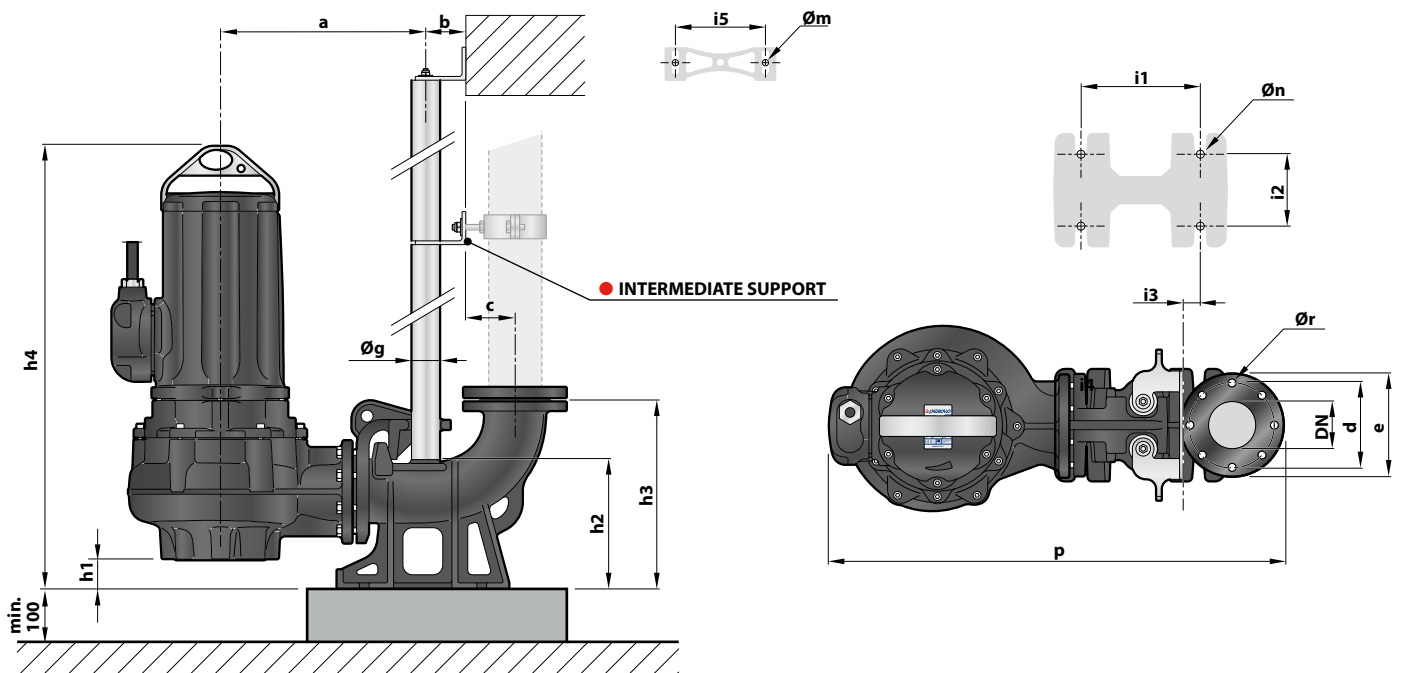

MODEL	Passage of solids mm	PORT DN	DIMENSIONS mm																	
			a	b	c	d	e	p	h1	h2	h3	h4	i1	i2	i3	i5	Øg	Øm	Øn	Ør
Three-phase																				
VXC4 /80	Ø 80	100	435	85.5	104.5	180	220	965	62	275	400	930	250	150	34	187	2"	13.5	22	18
MC4 /80																				