

## Submersible pumps

-  Sewage water
-  Domestic use
-  Civil use
-  Industrial use



### PERFORMANCE RANGE

- Flow rate up to **750 l/min** (45 m<sup>3</sup>/h)
- Head up to **15.5 m**

### APPLICATION LIMITS

- **5 m** maximum immersion depth (with a sufficiently long power cable)
- Maximum liquid temperature **+40 °C**
- Passage of solids:
  - up to **Ø 40 mm** for VX /35
  - up to **Ø 50 mm** for VX /50
- Minimum immersion depth for continuous service:
  - **290 mm** for VX 8 and VX 10
  - **330 mm** for VX 15
  - **360 mm** for VX 20

### CONSTRUCTION AND SAFETY STANDARDS

- Power cable length:
  - **5 m** for VX8-10/35, VX8-10/50
  - **10 m** for VX15/35, VX15/50
- Float switch for single-phase versions

EN 60335-1  
IEC 60335-1  
CEI 61-150

EN 60034-1  
IEC 60034-1  
CEI 2-3



### CERTIFICATIONS

Company with management system certified DNV ISO 9001: QUALITY



### INSTALLATION AND USE

VX pumps are recommended for domestic, civil and industrial applications in all cases where the water contains suspended solids up to Ø 50 mm, for example **groundwater, surface water, sewage and dirty water**.

They are for example suitable for draining flooded areas such as cellars, underground car parks, car washes, for emptying cesspools and for sewage disposal.

These pumps distinguish themselves for their reliability, which can be best appreciated under automatic operating conditions in fixed installations.

### PATENTS - TRADE MARKS - MODELS

- Patent n. EP2313658
- Patent n. IT0001428923

### OPTIONS AVAILABLE ON REQUEST

- VX8-10 pumps with a **10 m** power cable.
  - ➔ N.B.: Standard EN 60335-2-41 states that the power cable must be 10 m long for outdoor applications
- Single-phase pumps without float switch
- Other voltages or 60 Hz frequency

### CHARACTERISTIC CURVES AND PERFORMANCE DATA

50 Hz n= 2900 min<sup>-1</sup>

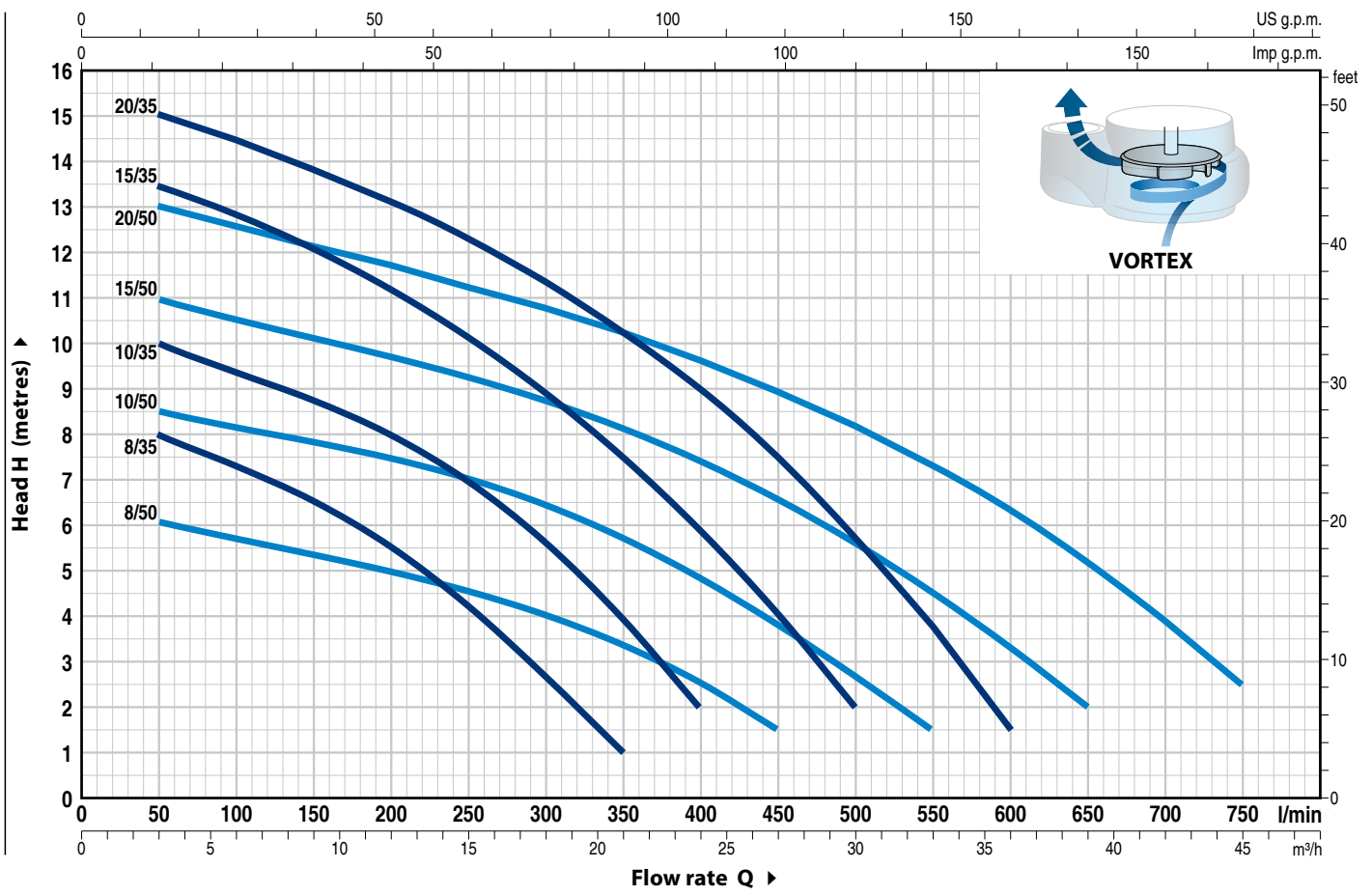

MODEL		POWER (P <sub>2</sub> )		Q	Flow rate														
Single-phase	Three-phase	kW	HP		m <sup>3</sup> /h	0	3	6	12	18	21	24	27	30	33	36	39	45	
				l/min	0	50	100	200	300	350	400	450	500	550	600	650	750		
VXm 8/35	VX 8/35	0.55	0.75	H metres	9	8	7.5	5.5	2.7	1									
VXm 10/35	VX 10/35	0.75	1		11	10	9.5	8	5.7	4	2								
VXm 15/35	VX 15/35	1.1	1.5		14	13.5	12.8	11.2	9	7.7	6	4	2						
VXm 20/35	VX 20/35	1.5	2		15.5	15	14.5	13	11.5	10.3	9	7.5	5.8	3.8	1.5				
VXm 8/50	VX 8/50	0.55	0.75		6.5	6	5.8	5	4	3.3	2.5	1.5							
VXm 10/50	VX 10/50	0.75	1		9	8.5	8.2	7.5	6.5	5.8	5	3.8	2.5	1.5					
VXm 15/50	VX 15/50	1.1	1.5		11.5	11	10.5	9.8	8.7	8	7.5	6.5	5.5	4.5	3.5	2			
VXm 20/50	VX 20/50	1.5	2		13.5	13	12.5	11.5	10.7	10	9.5	9	8	7.5	6.5	5	2.5		

Q = Flow rate H = Total manometric head

Tolerance of characteristic curves in compliance with EN ISO 9906 Grade 3B.

## POS. COMPONENT CONSTRUCTION CHARACTERISTICS

<b>1 PUMP BODY</b>	Cast iron with an Epoxy Electro Coating treatment for a greater resistance to corrosion, with threaded port in compliance with ISO 228/1
<b>2 BASE</b>	Stainless steel AISI 304
<b>3 IMPELLER</b>	VORTEX type AISI 304 stainless steel. The VORTEX impeller allows the pumping of solid bodies with a diameter of up to 50 mm and thanks to its particular geometry it ensures a safe anti-clogging operation.
<b>4 MOTOR CASING</b>	Stainless steel AISI 304
<b>5 MOTOR CASING PLATE</b>	Stainless steel AISI 304 for <b>VX 8-10</b> Cast iron with an Epoxy Electro Coating treatment for <b>VX 15-20</b>
<b>6 MOTOR SHAFT</b>	Stainless steel AISI 431

### 7 DOUBLE MECHANICAL SEAL IN OIL CHAMBER

Seal Model	Shaft Diameter	Position	Materials		
			Stationary ring	Rotational ring	Elastomer
MG1-14D SIC	Ø 14 mm	Motor side	Silicon carbide	Graphite	NBR
		Pump side	Silicon carbide	Silicon carbide	NBR

Double mechanical seal with an intermediate oil chamber, with silicon carbide chute slides for a greater resistance to abrasion and wear and for a longer life of the pump.

### 8 BEARINGS

Pump	Model
VX 8-10	6203 ZZ / 6203 ZZ
VX 15-20	6303 2RS - C3 / 6203 ZZ

### 9 CAPACITOR EN 60252-1/A1

(only for single-phase versions)

### 10 ELECTRIC MOTOR

Electric motors produced to a high quality standard, subjected to the most rigorous checks to ensure excellent insulation. The impregnation of the winding, achieved with high quality resins, is followed by treatment in an oven for up to eight hours, thus ensuring the long working life of the motor.

**VXm:** single-phase 230 V - 50 Hz  
with thermal overload protector incorporated into the winding

**VX:** three-phase 400 V - 50 Hz

- Insulation: class F
- Protection: IP X8

### 11 POWER CABLE

Power cable encapsulated in epoxy resin both in the area of the grommets and at the point where the wires exit the sheath, resulting in an absolute insulation from moisture and water infiltration.

H07 RN-F" type  
(with Schuko plug for single-phase versions only)

#### Standard length:

- 5 metres for VX 8-10,
- 10 metres for VX 15-20

### 12 FLOAT SWITCH

(only for single-phase versions)

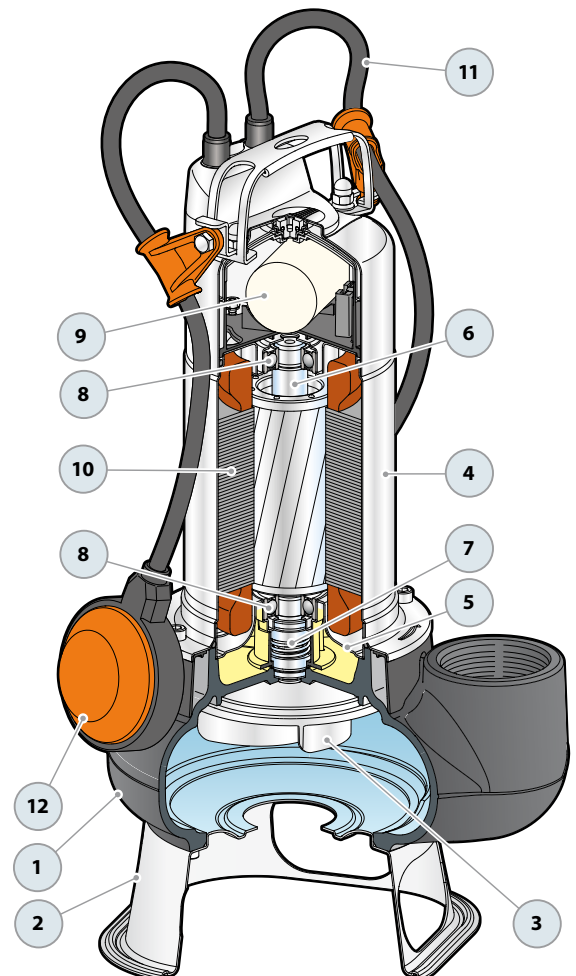

## DIMENSIONS AND WEIGHT

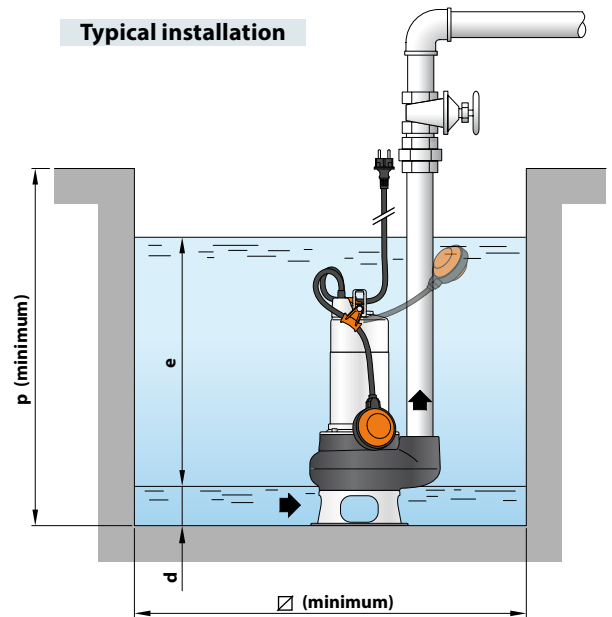
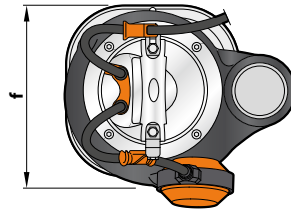
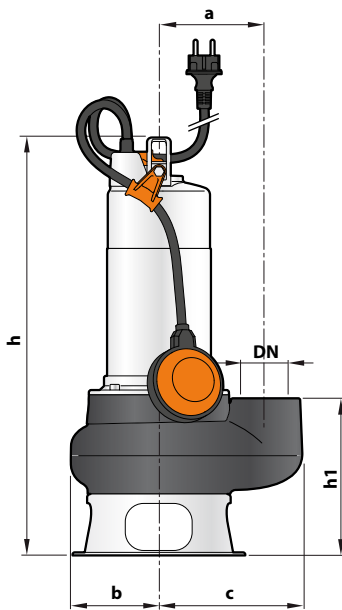

MODEL		PORT DN	Passage of solids	DIMENSIONS mm										kg	
Single-phase	Three-phase			a	b	c	f	h	h1	d	e	p	Ø	1~	3~
VXm 8/35	VX 8/35	1½"	Ø 40 mm	115	95	148	200	425	158	55	variable	500	500	13.7	12.6
VXm 10/35	VX 10/35							440						15.2	14.0
VXm 15/35	VX 15/35							473						18.0	16.4
VXm 20/35	VX 20/35							503						20.2	18.0
VXm 8/50	VX 8/50	2"	Ø 50 mm	115	95	155	200	436	169	60		500	500	14.2	13.1
VXm 10/50	VX 10/50							451						15.7	14.5
VXm 15/50	VX 15/50							484						18.5	16.9
VXm 20/50	VX 20/50							514						20.7	18.5

## ABSORPTION

MODEL	VOLTAGE	
	230 V	240 V
<b>Single-phase</b>		
VXm 8/35	4.3 A	4.2 A
VXm 10/35	5.5 A	5.4 A
VXm 15/35	7.0 A	6.9 A
VXm 20/35	9.6 A	9.4 A
VXm 8/50	4.3 A	4.2 A
VXm 10/50	5.5 A	5.4 A
VXm 15/50	7.0 A	6.9 A
VXm 20/50	9.6 A	9.4 A

MODEL	VOLTAGE			
	230 V	400 V	240 V	415 V
<b>Three-phase</b>				
VX 8/35	2.8 A	1.6 A	2.7 A	1.6 A
VX 10/35	3.8 A	2.2 A	3.6 A	2.1 A
VX 15/35	4.7 A	2.7 A	4.5 A	2.6 A
VX 20/35	6.4 A	3.7 A	6.1 A	3.5 A
VX 8/50	2.8 A	1.6 A	2.7 A	1.6 A
VX 10/50	3.8 A	2.2 A	3.6 A	2.1 A
VX 15/50	4.7 A	2.7 A	4.5 A	2.6 A
VX 20/50	6.4 A	3.7 A	6.1 A	3.5 A

## CAPACITOR

MODEL	CAPACITANCE
<b>Single-phase</b>	(230 V or 240 V)
VXm 8/35	20 µF 450 VL
VXm 10/35	25 µF 450 VL
VXm 15/35	35 µF 450 VL
VXm 20/35	35 µF 450 VL
VXm 8/50	20 µF 450 VL
VXm 10/50	25 µF 450 VL
VXm 15/50	35 µF 450 VL
VXm 20/50	35 µF 450 VL

## PALLETIZATION

MODEL		GROUPAGE n. pumps	CONTAINER n. pumps
Single-phase	Three-phase		
VXm 8/35	VX 8/35	45	60
VXm 10/35	VX 10/35	45	60
VXm 15/35	VX 15/35	30	45
VXm 20/35	VX 20/35	30	45
VXm 8/50	VX 8/50	45	60
VXm 10/50	VX 10/50	45	60
VXm 15/50	VX 15/50	30	60
VXm 20/50	VX 20/50	30	45