

VX

VORTEX submersible pumps



MADE IN ITALY

 **PEDROLLO**[®]
the spring of life

VORTEX

- ※ **VX** electric pumps are **VORTEX** pumps, specially designed and made using the most advanced expertise of Pedrollo that can rely on 50 years of experience in pump construction.
- ※ **Made from stainless steel and exceptionally sturdy, abrasion-resistant, long-lasting, heavy-gauge cast iron, VX pumps are equipped with VORTEX type impellers, highly recommended for their reliability and low risk of clogging. These pumps are therefore suitable for draining foul, waste water, sewage, water mixed with solids, activated and putrid sludge.**
- ※ Thanks to enhanced oversizing of the electric motor, shaft and bearings, these new **VX** electric pumps guarantee unprecedented service life, high hydraulic performance, low operating costs and easy maintenance. The sturdy electric motor construction allows continuous mode operation even if partially uncovered.



PERFORMANCE RANGE

- Flow rate up to **1800 l/min** (108 m³/h)
- Head up to **26 m**

APPLICATION LIMITS

- **10 m** maximum immersion depth below the water level (with a properly long power cable)
- Maximum liquid temperature **+40 °C**
- Passage of suspended solids:
 - up to **Ø 50 mm** for VX 50
 - up to **Ø 65 mm** for VX 65
 - up to **Ø 80 mm** for VX 80
- **500 mm** minimum immersion depth for continuous service

CONSTRUCTION AND SAFETY STANDARDS

- **10 m** power cable length

INSTALLATION AND USE

Recommended in all installations for pumping sewage with suspended solids (up to 80 mm in diameter), wastewater, rain water, liquid manure, municipal blackwater and industrial waste.

Suitable for installation in sewers, tunnels, excavations, canals, underground parking lots, etc.

PATENTS - TRADE MARKS - MODELS

- Registered EU Design No. 003863158-0002

OPTIONS AVAILABLE ON REQUEST

- Other voltage ratings or 60 Hz frequency

WARRANTY

2 years in accordance with our general terms of sale

CHARACTERISTIC CURVES AND PERFORMANCE DATA

50 Hz n= 2900 min⁻¹

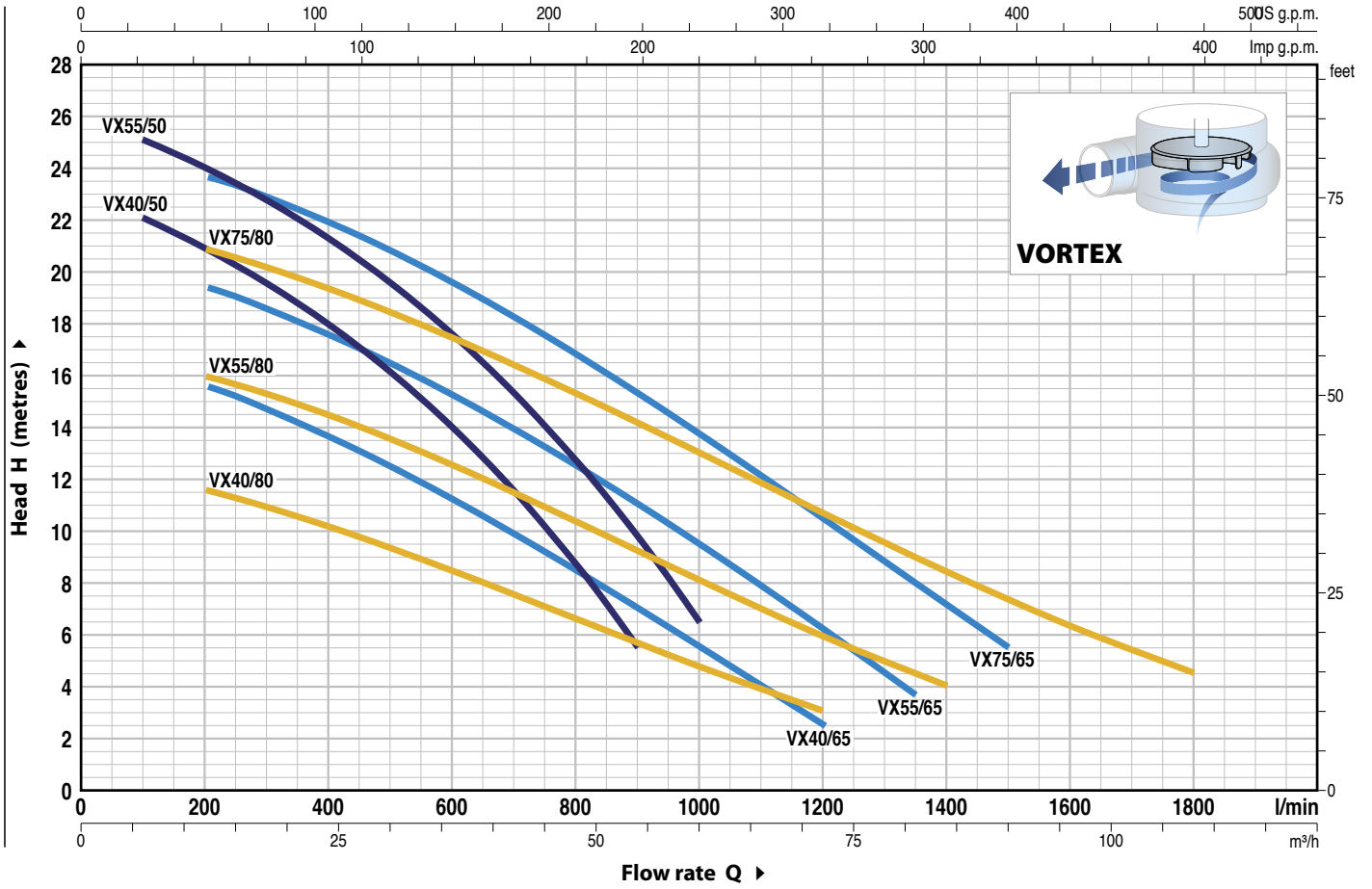

MODEL	POWER (P ₂)		Q	Flow rate												
	kW	HP		m ³ /h	0	6	12	18	24	30	36	42	48	54	60	
Three-phase				0	100	200	300	400	500	600	700	800	900	1000		
VX 40/50	3	4	H metres	23	22	20.8	19.5	17.9	16.1	13.9	11.5	8.7	5.5			
VX 55/50	4	5.5		26	25	23.9	22.7	21.2	19.5	17.5	15.3	12.7	9.8	6.5		

MODEL	POWER (P ₂)		Q	Flow rate												
	kW	HP		m ³ /h	0	12	18	27	36	45	54	63	72	81	90	
Three-phase				0	200	300	450	600	750	900	1050	1200	1350	1500		
VX 40/65	3	4	H metres	17	15.6	14.7	13.1	11.2	9.2	7	4.8	2.5				
VX 55/65	4	5.5		20.7	19.4	18.5	17	15.2	13.2	11	8.7	6.2	3.7			
VX 75/65	5.5	7.5		24.8	23.6	22.9	21.4	19.6	17.5	15.2	12.9	10.5	8	5.5		

MODEL	POWER (P ₂)		Q	Flow rate												
	kW	HP		m ³ /h	0	12	24	36	48	60	72	84	96	108		
Three-phase				0	200	400	600	800	1000	1200	1400	1600	1800			
VX 40/80	3	4	H metres	12.5	11.5	10.2	8.5	6.7	4.9	3						
VX 55/80	4	5.5		16.5	16	14.4	12.5	10.3	8.1	6	4					
VX 75/80	5.5	7.5		22	21	19.2	17.4	15.2	13	10.7	8.4	6.4	4.5			

Q = Flow rate H = Total manometric head

Tolerance of characteristic curves in compliance with EN ISO 9906 Grade 3B.

POS. COMPONENT

CONSTRUCTION CHARACTERISTICS

1	PUMP BODY	Cast iron with Epoxy Electro Coating treatment, with flanged and threaded port in compliance with ISO 228/1
2	IMPELLER	Cast iron with Epoxy Electro Coating treatment, VORTEX type
3	MOTOR CASING	AISI 304 stainless steel
4	MOTOR CASING PLATE	Cast iron with Epoxy Electro Coating treatment
5	MOTOR SHAFT	AISI 431 stainless steel

6 TWO MECHANICAL SEALS SEPARATED BY AN OIL CHAMBER

	Seal Model	Shaft Diameter	Position	Materials		
				Stationary ring	Rotational ring	Elastomer
VX 50	ED560-25	Ø 25 mm	Motor side	Silicon carbide	Graphite	NBR
			Pump side	Silicon carbide	Silicon carbide	NBR
VX 65-80	AR-27	Ø 27 mm	Motor side	Silicon carbide	Graphite	NBR
	AR-25	Ø 25 mm	Pump side	Silicon carbide	Silicon carbide	NBR

7 BEARINGS 6306 ZZ C3 / 6304 ZZ C3

8 ELECTRIC MOTOR

three-phase 400 V - 50 Hz

with automatically resettable thermal motor protector built into the motor (THREE-PHASE)

- Insulation: class F
- Protection: IP X8

9 POWER CABLE

"H07 RN-F" type

Standard length 10 metres

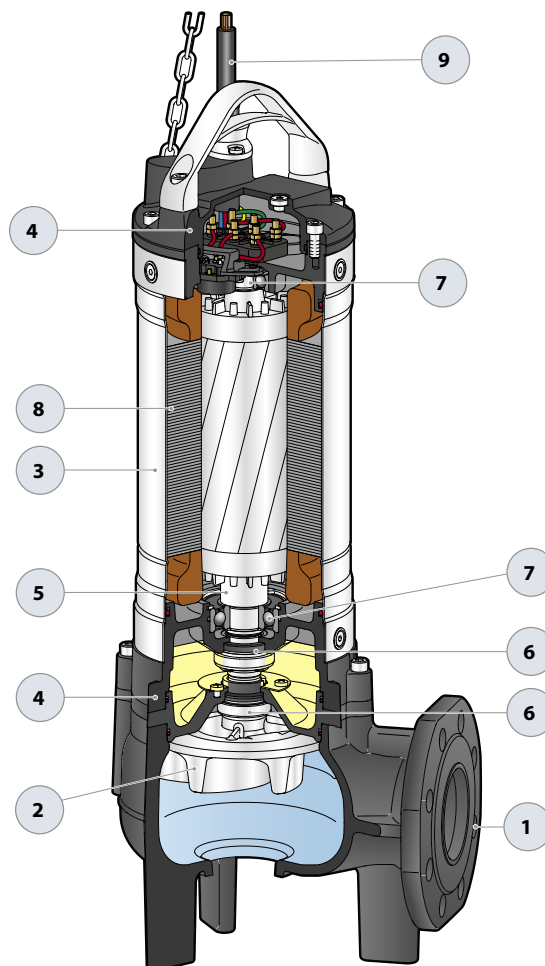

VX 50 - 65 - 80

DIMENSIONS AND WEIGHT

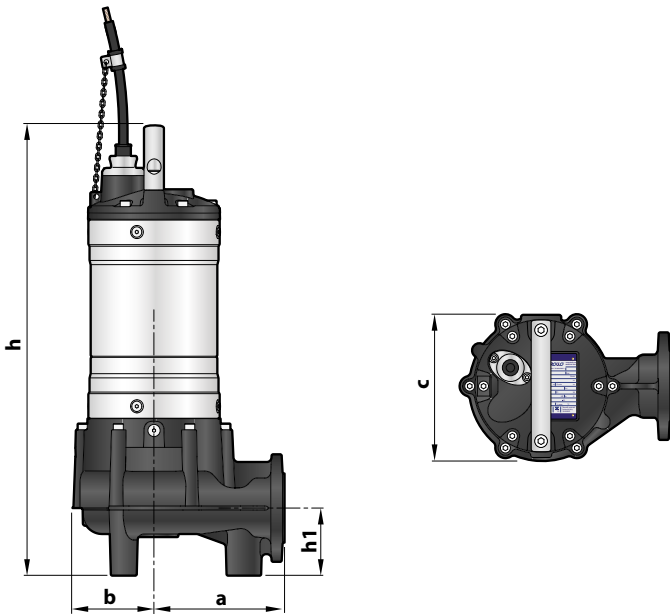

Typical installation

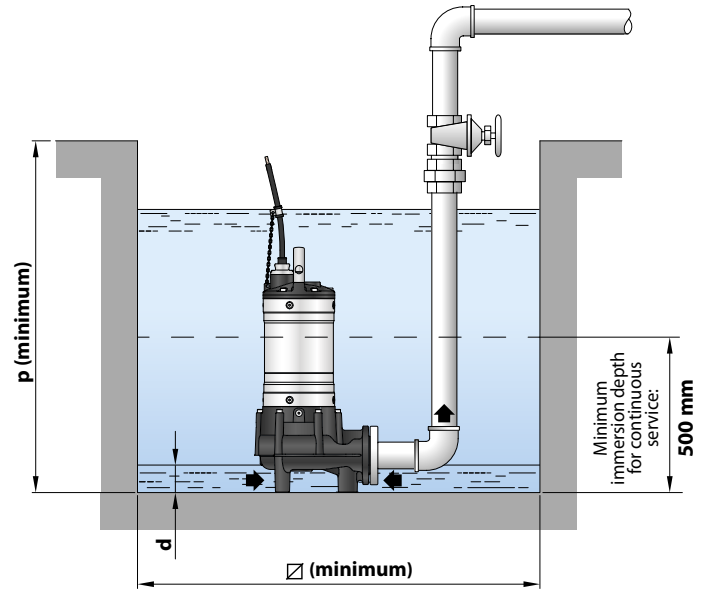

MODEL	Passage of solids	DIMENSIONS mm								kg
		a	b	c	h	h1	d	p	Ø	
Three-phase										3~
VX 40/50	Ø 50 mm	170	106	193	602	100	55	700	500	50.0
VX 55/50					642					58.2
VX 40/65	Ø 65 mm	170	107	196	630	121	70	800	500	53.3
VX 55/65					670					60.0
VX 75/65					700					65.0
VX 40/80	Ø 80 mm	178	107	210	655	150	85	800	500	54.8
VX 55/80					695					61.5
VX 75/80					725					66.5

PORT FLANGE

MODEL	FLANGE	F	K	D	HOLES		
					N°	Ø (mm)	
Three-phase	DN		mm	mm			
VX 40/50	50	2"	125	150	4	18	
VX 55/50	(PN10)						
VX 40/65	65	2½"	145	185	8	18	
VX 55/65							(PN10)
VX 75/65							
VX 40/80	80	3"	160	200	8	18	
VX 55/80							(PN10)
VX 75/80							

ABSORPTION

MODEL	VOLTAGE
Three-phase	400 V
VX 40/50	5.8 A
VX 55/50	7.0 A
VX 40/65	6.2 A
VX 55/65	7.7 A
VX 75/65	12.7 A
VX 40/80	6.0 A
VX 55/80	8.5 A
VX 75/80	13.5 A

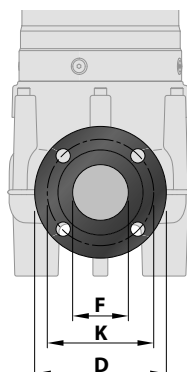

SEWAGE LIFTING SYSTEM VX40-50 – 65

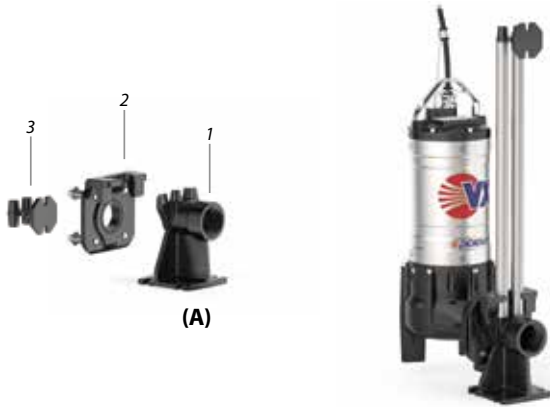

HORIZONTAL DELIVERY VERSION WITH ¾" GUIDE TUBES (A)

For VX /40	Code ASSPVX40	DN 2"
For VX /50	Code ASSPVX50	DN 2"

Kit comprising:

1. footing connection;
2. slide guide with screws and seals;
3. support for guide tubes.

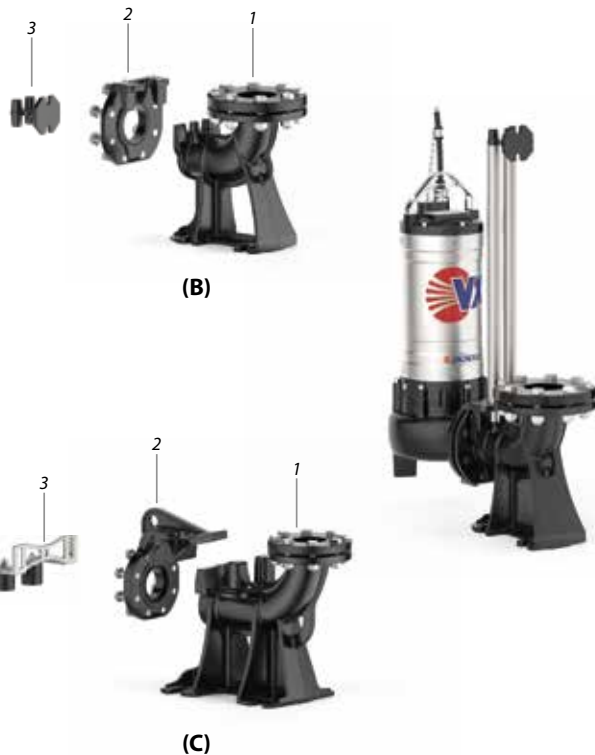

VERTICAL DELIVERY VERSION WITH ¾" GUIDE TUBES (B)

For VX /40	Code ASSPVX40V	DN 2½"
For VX /50	Code ASSPVX503V	DN 2½"
For VX /65,	Code ASSPVX653V	DN 3"

Kit comprising:

1. footing connection complete with counterflange;
2. slide guide with screws and seals;
3. support for guide tubes.

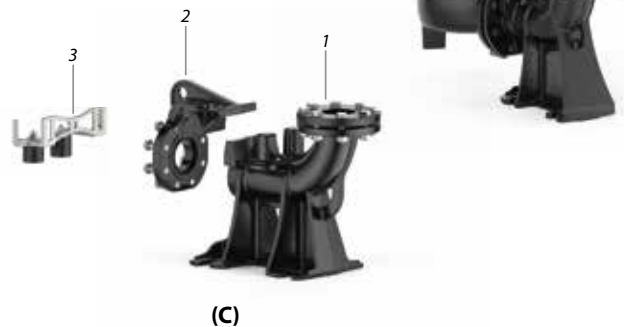

VERTICAL DELIVERY VERSION WITH 2" GUIDE TUBES (C)

For VX /50	Code ASSPVX50V	DN 3"
For VX /65,	Code ASSPVX65V	DN 3"
For VX /80,	Code ASSVXCF0705V	DN 3"

Kit comprising:

1. footing connection complete with counterflange;
2. slide guide with screws and seals;
3. support for guide tubes.

ACCESSORIES AVAILABLE ON ORDER

SLIDE GUIDE (Can also be ordered separately)

For VX /40 with guide tubes Ø ¾"	Code ASSFL011
For VX /50 with guide tubes Ø ¾"	Code ASSFL009
For VX /65, with guide tubes Ø ¾"	Code ASSFL010
For VX /50 with guide tubes Ø 2"	Code ASSFL050
For VX /65, with guide tubes Ø 2"	Code ASSFL065
For VX /80, with guide tubes Ø 2"	Code ASSFL072

- Complete with screws and seals

INTERMEDIATE SUPPORT (on request)

For guide tubes Ø ¾"	Code 859SV340INTFA
For guide tubes Ø 2"	Code 859SV349INTFA

GUIDE TUBES (AISI 304 stainless steel)

Guide tubes Ø ¾"	Code 54SARTG005
Guide tubes Ø 2"	Code 54SARTG006

- To ensure stability, install the intermediate support:
 - every 2 metres with ¾" guide tubes (mandatory);
 - every 3 metres with 2" guide tubes (recommended).
- Maximum length of the tube plank: 6 metres



DIMENSIONS (Horizontal delivery version)

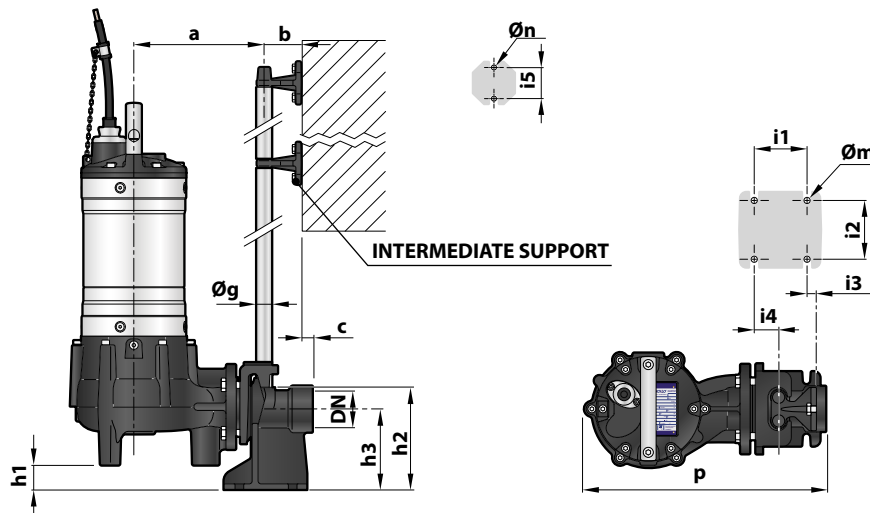

MODEL	Passage of solids mm	PORT DN	DIMENSIONS mm														
			a	b	c	p	h1	h2	h3	i1	i2	i3	i4	i5	Øg	Øm	Øn
VX /50	Ø 50	2"	214	61	17	400	30	165	130	85	94	16	40	50	¾"	12	11

DIMENSIONS (Vertical delivery version)

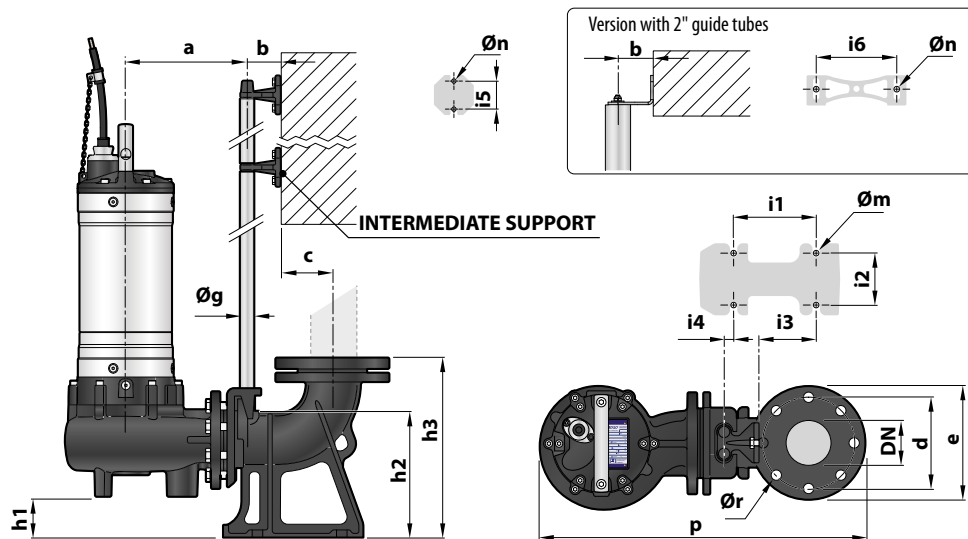

Version with ¾" guide tubes

MODEL	Passage of solids mm	PORT DN	DIMENSIONS mm																	
			a	b	c	d	e	p	h1	h2	h3	i1	i2	i3	i4	i5	Øg	Øm	Øn	Ør
VX /50	Ø 50	2½"	211	61	52	125	165	506	28	164	216	120	72	62	3	50	¾"	14	11	18
VX /65	Ø 65	3"	213		69	150	190	537	48	216	280	130	112	84	15					

Version with 2" guide tubes

MODEL	Passage of solids mm	PORT DN	DIMENSIONS mm																		
			a	b	c	d	e	p	h1	h2	h3	i1	i2	i3	i4	i5	i6	Øg	Øm	Øn	Ør
VX /50	Ø 50	3"	319	86	95	160	200	706	107	264	392	250	150	34	-	80	186	2"	22	13.5	18
VX /65	Ø 65							697	86												
VX /80	Ø 80							714	57												

TYPICAL INSTALLATION

1. Pump
2. Footing connection
3. Guide tubes
4. Support for guide tubes
5. Lifting chain
6. Control box
7. Alarm float switch
8. Starting float switch
9. Stop float switch
10. Non-return valve

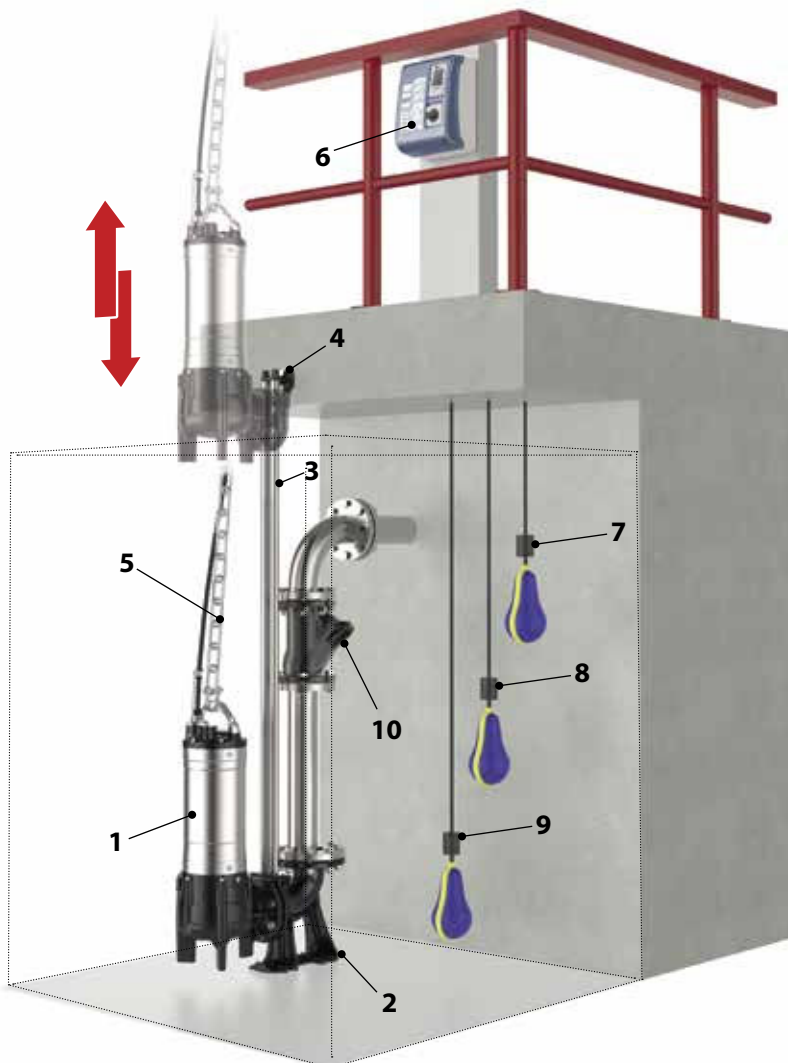

*The features and specifications here in are in no way binding for the manufacturer.
Pedrollo S.p.A. reserves the right to modify the product in accordance with its production improvement policy at any time and without prior notice.*

Pedrollo S.p.A.

Via Enrico Fermi, 7 - 37047 San Bonifacio (Verona) Italy
tel. +39 045 6136311 - fax +39 045 7614663
vendite@pedrollo.com - sales@pedrollo.com - www.pedrollo.com

MADE IN ITALY