

Submersible pumps in stainless steel

-  Sewage water
-  Domestic use
-  Civil use
-  Industrial use



PERFORMANCE RANGE

- Flow rate up to **850 l/min** (51 m³/h)
- Head up to **17 m**

APPLICATION LIMITS

- **5 m** maximum immersion depth
- Maximum liquid temperature **+40 °C**
- Passage of suspended solids up to **Ø 50 mm**
- Minimum immersion depth for continuous service:
 - **290 mm** for BC 10/50-ST
 - **330 mm** for BC 15/50-ST
 - **360 mm** for BC 20/50-ST

CONSTRUCTION AND SAFETY STANDARDS

- **10 m** long power cable
- Float switch for single-phase versions

EN 60335-1
IEC 60335-1
CEI 61-150

EN 60034-1
IEC 60034-1
CEI 2-3



CERTIFICATIONS

Company with management system
certified DNV ISO 9001: QUALITY



INSTALLATION AND USE

BC-ST submersible pumps in stainless steel are recommended for draining **dirty and sewage water** in domestic, civil and industrial applications. They come equipped with a **DOUBLE-CHANNEL** impeller and are capable of pumping liquids containing short fibred suspended solids up to Ø 50 mm. They are ideal for pumping sewage, waste water, surface water and water mixed with mud in locations such as blocks of flats and detached houses.

These pumps distinguish themselves for their reliability, which can be best appreciated under automatic operating conditions in fixed installations.

PATENTS - TRADE MARKS - MODELS

- Patent n. EP2313658
- Patent n. IT0001428923

OPTIONS AVAILABLE ON REQUEST

- Single-phase pumps without float switch
- AISI 316L stainless steel pump shaft
- Other voltages or 60 Hz frequency

CHARACTERISTIC CURVES AND PERFORMANCE DATA

50 Hz n= 2900 min⁻¹

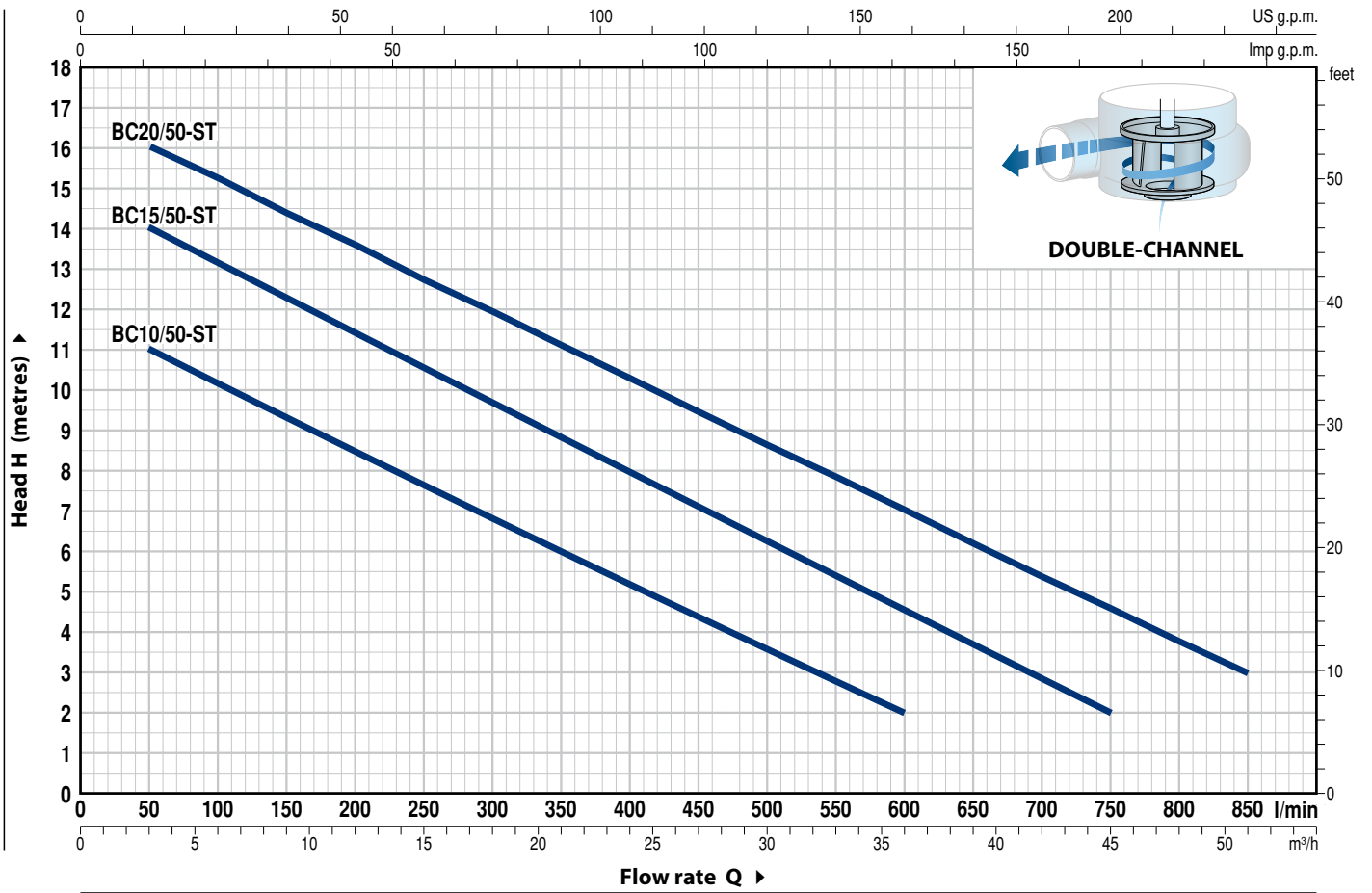

MODEL		POWER (P ₂)		Q	Flow rate														
Single-phase	Three-phase	kW	HP		m ³ /h	0	3	6	12	18	24	30	36	42	45	51			
				l/min	0	50	100	200	300	400	500	600	700	750	850				
BCm 10/50-ST	BC 10/50-ST	0.75	1	H metres	12	11	10	8.5	7	5	3.6	2							
BCm 15/50-ST	BC 15/50-ST	1.1	1.5		15	14	13	11.5	9.7	8	6.3	4.6	2.9	2					
BCm 20/50-ST	BC 20/50-ST	1.5	2		17	16	15.3	13.5	12	10.3	8.6	7.0	5.3	4.5	3				

Q = Flow rate H = Total manometric head

Tolerance of characteristic curves in compliance with EN ISO 9906 Grade 3B.

POS. COMPONENT CONSTRUCTION CHARACTERISTICS

1 PUMP BODY	Stainless steel AISI 304 with threaded port in compliance with ISO 228/1
2 BASE	Stainless steel AISI 304
3 IMPELLER	Precision cast stainless steel AISI 304 DOUBLE-CHANNEL type. The double-channel impeller produces excellent performance and high energy efficiency, developing higher pressure and ensuring the pumping of solids up to 50 mm in diameter. Definitely the most highly performing solution for draining wastewater.
4 MOTOR CASING	Stainless steel AISI 304
5 MOTOR CASING PLATE	Stainless steel AISI 304 for BC 10/50-ST Cast iron with an Epoxy Electro Coating treatment for BC 15/50-ST, BC 20/50-ST
6 MOTOR SHAFT	Stainless steel AISI 431

7 DOUBLE MECHANICAL SEAL IN OIL CHAMBER

Seal Model	Shaft Diameter	Position	Materials		
			Stationary ring	Rotational ring	Elastomer
MG1-14D SIC	Ø 14 mm	Motor side	Silicon carbide	Graphite	NBR
		Pump side	Silicon carbide	Silicon carbide	NBR

Double mechanical seal in oil chamber, with silicon carbide chute slides for a greater resistance to abrasion and wear and for a longer life of the pump.

8 BEARINGS

Pump	Model
BC 10/50-ST	6203 ZZ / 6203 ZZ
BC 15/50-ST BC 20/50-ST	6303 2RS - C3 / 6203 ZZ

9 CAPACITOR

(only for single-phase versions)

10 ELECTRIC MOTOR

Electric motors produced to a high quality standard, subjected to the most rigorous checks to ensure excellent insulation. The impregnation of the winding, achieved with high quality resins, is followed by treatment in an oven for up to eight hours, thus ensuring the long working life of the motor.

BCm-ST: single-phase 230 V - 50 Hz
with thermal overload protector incorporated into the winding

BC-ST: three-phase 400 V - 50 Hz

- Insulation: class F
- Protection: IP X8

11 POWER CABLE

Power cable encapsulated in epoxy resin both in the area of the grommets and at the point where the wires exit the sheath, resulting in an absolute insulation from moisture and water infiltration.

H07 RN-F" type
(with Schuko plug for single-phase versions only)

Standard length 10 metres

12 EXTERNAL FLOAT SWITCH

(only for single-phase versions)

13 TILTING DEVICE FOR THE FLOAT CABLE

(only for single-phase versions)

Patent n. IT0001428923

14 TEAR-PROOF DEVICE FOR THE POWER CABLE

Patent n. EP2313658

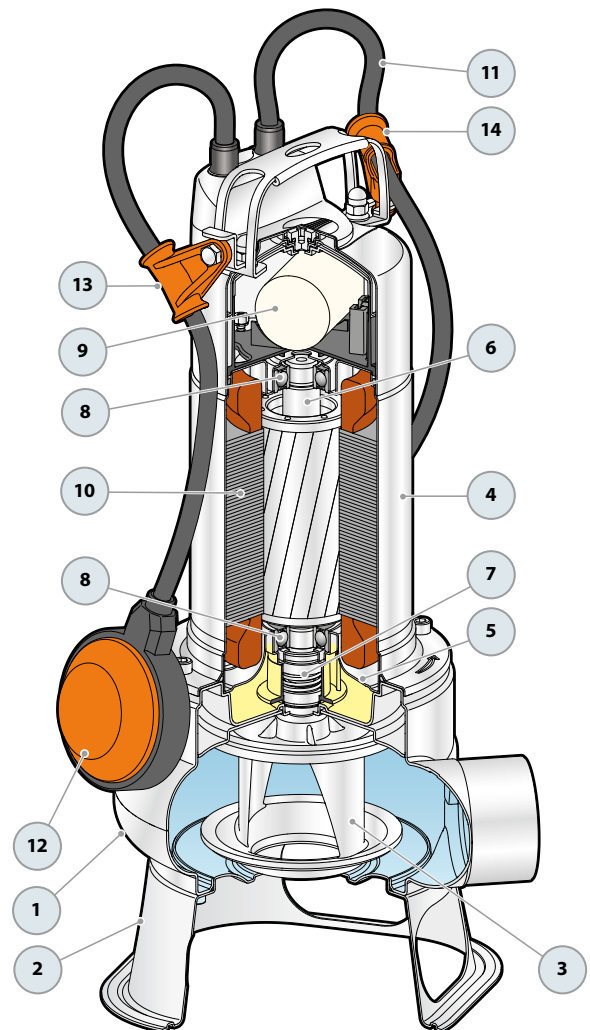

DIMENSIONS AND WEIGHT

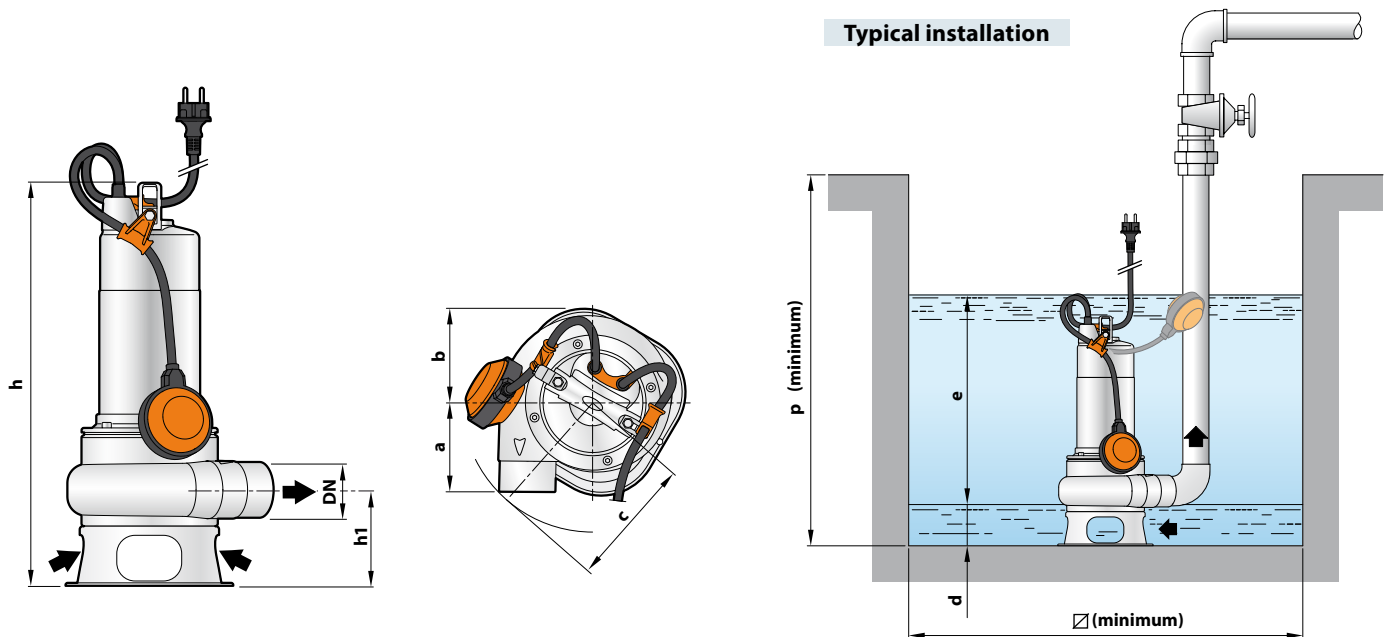

MODEL		PORT DN	Passage of solids	DIMENSIONS mm									kg	
Single-phase	Three-phase			a	b	c	h	h1	d	e	p	Ø	1~	3~
BCm 10/50-ST	BC 10/50-ST	2"	Ø 50 mm	102	95	145	450	107	60	variable	500	500	13.4	12.2
BCm 15/50-ST	BC 15/50-ST						483						16.0	14.4
BCm 20/50-ST	BC 20/50-ST						513						18.2	16.0

ABSORPTION

MODEL	VOLTAGE	
	230 V	240 V
BCm 10/50-ST	5.5 A	5.4 A
BCm 15/50-ST	8.0 A	7.8 A
BCm 20/50-ST	10.0 A	9.8 A

MODEL	VOLTAGE			
	230 V	400 V	240 V	415 V
BC 10/50-ST	3.8 A	2.2 A	3.6 A	2.1 A
BC 15/50-ST	5.3 A	3.1 A	5.1 A	2.9 A
BC 20/50-ST	6.7 A	3.9 A	6.5 A	3.7 A

CAPACITORS

MODEL	CAPACITANCE
Single-phase	(230 V or 240 V)
BCm 10/50-ST	25 µF 450 VL
BCm 15/50-ST	35 µF 450 VL
BCm 20/50-ST	35 µF 450 VL

PALLETIZATION

MODEL		GROUPAGE	CONTAINER
Single-phase	Three-phase	n. pumps	n. pumps
BCm 10/50-ST	BC 10/50-ST	45	60
BCm 15/50-ST	BC 15/50-ST	30	45
BCm 20/50-ST	BC 20/50-ST	30	45

SEWAGE LIFTING SYSTEM VX-ST – BC-ST

HORIZONTAL DELIVERY VERSION WITH ¾" GUIDE TUBES

For VX /35-ST	Cod. ASSPVX35ST	DN 2"
For VX /50-ST , BC /50-ST	Cod. ASSPVX50ST	DN 2"

Kit consisting of:

- 1) footing connection
- 2) slide guide with ring nut and seal
- 3) support for the guide tubes



VERTICAL DELIVERY VERSION WITH ¾" GUIDE TUBES

For VX /35-ST	Cod. ASSPVX35STV	DN 2½"
For VX /50-ST, BC /50-ST	Cod. ASSPVX50STV	DN 2½"

Kit consisting of:

- 1) footing connection complete with counterflange
- 2) slide guide with ring nut and seal
- 3) support for the guide tubes



ACCESSORIES CAN BE ORDERED

SLIDE GUIDE (also to be ordered separately)

For VX /35-ST	Cod. ASSFL005
For VX /50-ST , BC /50-ST	Cod. ASSFL006

Complete with ring nut and seal



INTERMEDIATE SUPPORT (on request)

For guide tubes Ø ¾"	Cod. 859SV340INTFA
----------------------	--------------------

In order to ensure stability, insert the intermediate support every 2 metres



GUIDE TUBES (AISI 304 stainless steel)

Guide tube Ø ¾"	Cod. 54SARTG005
-----------------	-----------------

Maximum length of the tube plank: 6 metres



DIMENSIONS (Horizontal delivery version)

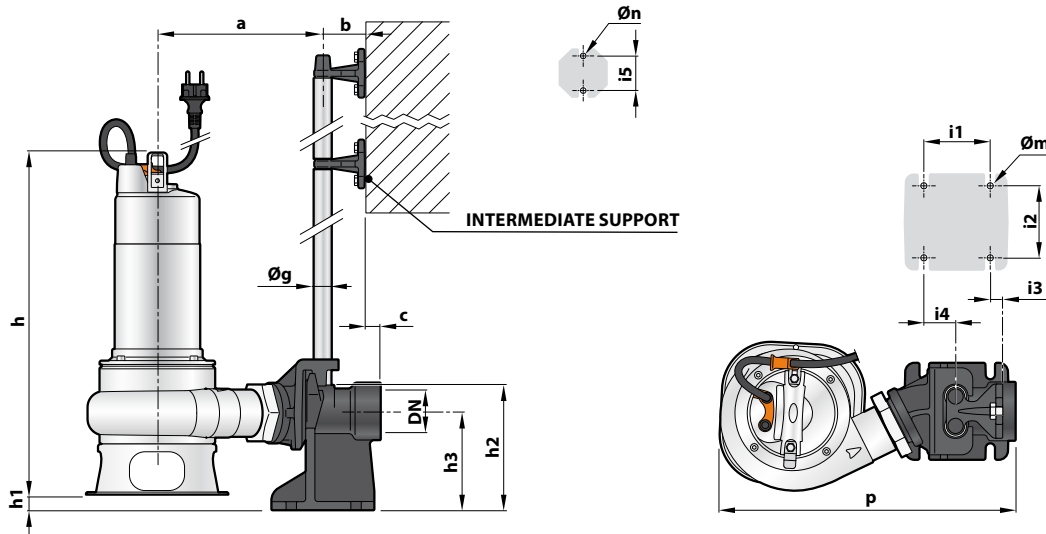

MODEL		Passage of solids mm	PORT DN	DIMENSIONS mm															
Single-phase	Three-phase			a	b	c	p	h	h1	h2	h3	i1	i2	i3	i4	i5	Øg	Øm	Øn
VXm 8/35 -ST	VX 8/35 -ST	40	2"	214			386	424	24										
VXm 10/35 -ST	VX 10/35 -ST							439											
VXm 15/35 -ST	VX 15/35 -ST							472											
VXm 20/35 -ST	VX 20/35 -ST							502											
VXm 8/50 -ST	VX 8/50 -ST	50	2"	221	61	17	372	435	23	165	130	85	94	16	40	50	¾"	12	11
VXm 10/50 -ST	VX 10/50 -ST							450											
VXm 15/50 -ST	VX 15/50 -ST							483											
VXm 20/50 -ST	VX 20/50 -ST							513											
BCm 10/50 -ST	BC 10/50 -ST	50	2"					450	26										
BCm 15/50 -ST	BC 15/50 -ST							483											
BCm 20/50 -ST	BC 20/50 -ST							513											

DIMENSIONS (Vertical delivery version)

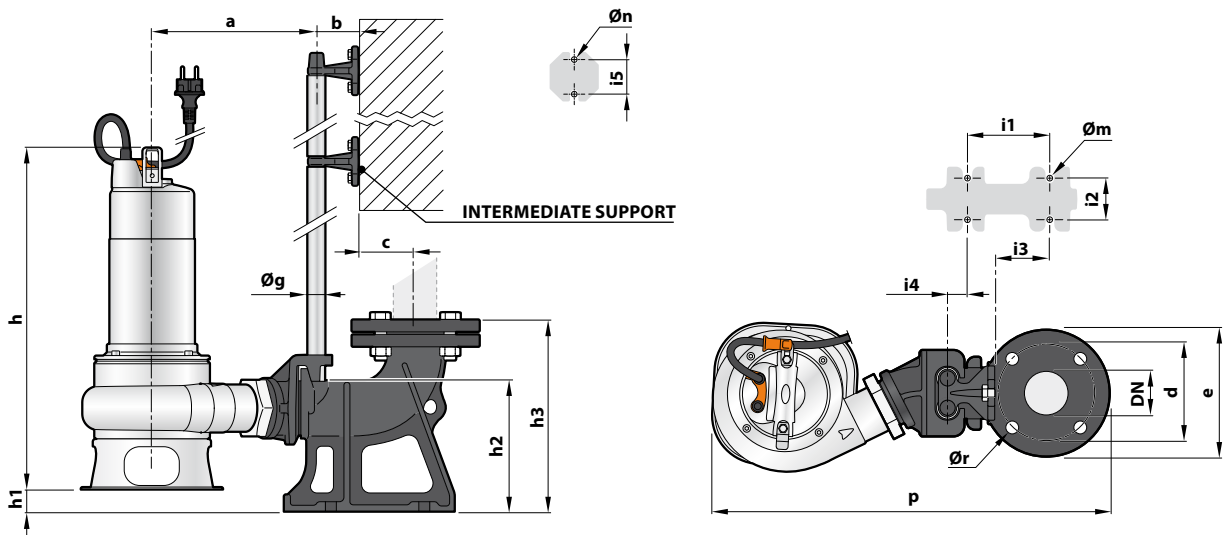

MODEL		Passage of solids mm	PORT DN	DIMENSIONS mm																	
Single-phase	Three-phase			a	b	c	d	e	p	h	h1	h2	h3	i1	i2	i3	i4	i5	Øg	Øm	Øn
VXm 8/35 -ST	VX 8/35 -ST	40	2½"	207				495	22												
VXm 10/35 -ST	VX 10/35 -ST																				439
VXm 15/35 -ST	VX 15/35 -ST																				472
VXm 20/35 -ST	VX 20/35 -ST																				502
VXm 8/50 -ST	VX 8/50 -ST	50	2½"	212	61	52	125	165	26	164	215	120	72	62	3	50	¾"	14	11	18	
VXm 10/50 -ST	VX 10/50 -ST																				435
VXm 15/50 -ST	VX 15/50 -ST																				450
VXm 20/50 -ST	VX 20/50 -ST																				483
BCm 10/50 -ST	BC 10/50 -ST	50	2½"					501	26												
BCm 15/50 -ST	BC 15/50 -ST																				450
BCm 20/50 -ST	BC 20/50 -ST																				483